

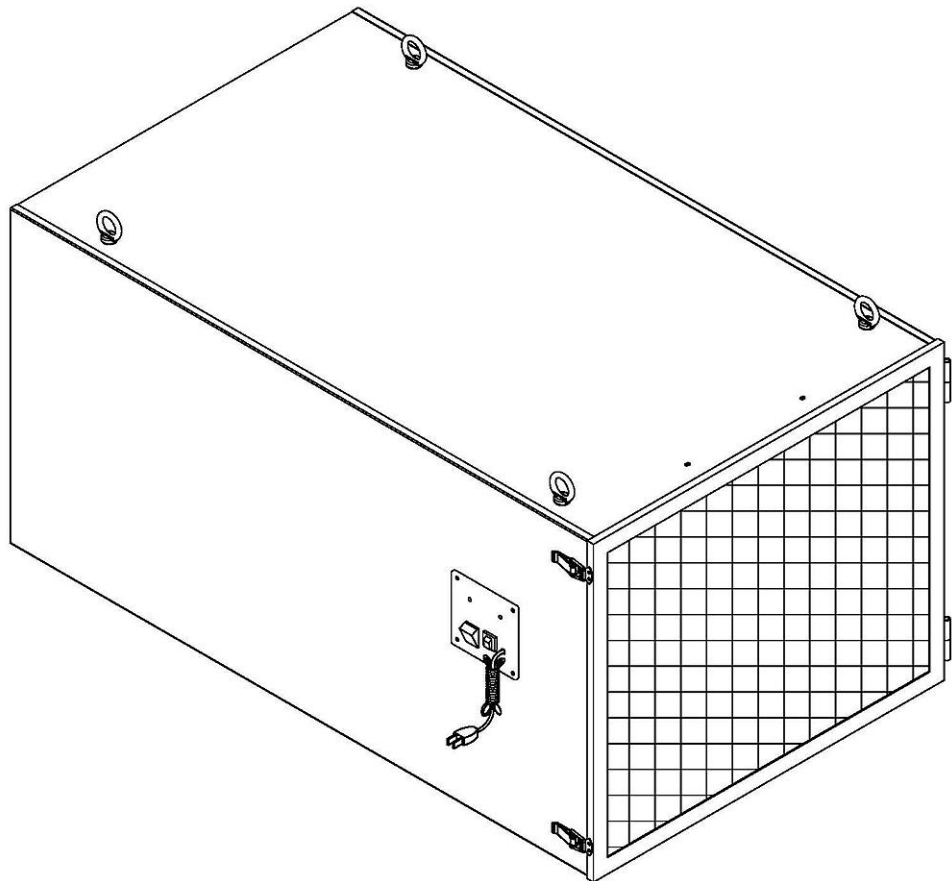

OPERATOR'S MANUAL

This .pdf document is bookmarked.



AIR FILTRATION SYSTEM MODEL: AFS-1600

Baileigh Industrial Holdings LLC,
P.O. Box 531
Manitowoc, WI 54221-0531
Phone: 920.684.4990
Fax: 920.684.3944
sales@baileigh.com

REPRODUCTION OF THIS MANUAL IN ANY FORM WITHOUT WRITTEN APPROVAL OF BAILEIGH INDUSTRIAL HOLDINGS LLC, IS PROHIBITED. Baileigh Industrial Holdings LLC, does not assume and hereby disclaims any liability for any damage or loss caused by an omission or error in this Operator's Manual, resulting from accident, negligence, or other occurrence.

Rev. 12/2021

Table of Contents

THANK YOU & WARRANTY	1
INTRODUCTION.....	3
GENERAL NOTES.....	3
SAFETY INSTRUCTIONS	4
SAFETY PRECAUTIONS	6
Dear Valued Customer:.....	6
TECHNICAL SPECIFICATIONS	9
TECHNICAL SUPPORT	9
UNPACKING AND CHECKING CONTENTS.....	10
Cleaning	10
INSTALLATION.....	11
Placement and Positioning	11
Filtering Performance	13
ASSEMBLY AND SET UP	14
ELECTRICAL.....	16
Power cord connection:	17
WIRING DIAGRAM.....	18
OPERATION.....	19
Remote Control Operation.....	19
PARTS DIAGRAM	20
Part List	21
MAINTENANCE	23
Changing Filters	23



THANK YOU & WARRANTY

Thank you for your purchase of a machine from Baileigh Industrial Holdings LLC. We hope that you find it productive and useful to you for a long time to come.

Inspection & Acceptance. Buyer shall inspect all Goods within ten (10) days after receipt thereof. Buyer's payment shall constitute final acceptance of the Goods and shall act as a waiver of the Buyer's rights to inspect or reject the goods unless otherwise agreed. If Buyer rejects any merchandise, Buyer must first obtain a Returned Goods Authorization ("RGA") number before returning any goods to Seller. Goods returned without a RGA will be refused. Seller will not be responsible for any freight costs, damages to goods, or any other costs or liabilities pertaining to goods returned without an RGA. Seller shall have the right to substitute a conforming tender. Buyer will be responsible for all freight costs to and from Buyer and repackaging costs, if any, if Buyer refuses to accept shipment. If Goods are returned in unsalable condition, Buyer shall be responsible for full value of the Goods. Buyer may not return any special-order Goods. Any Goods returned hereunder shall be subject to a restocking fee equal to 30% of the invoice price.

Specifications. Seller may, at its option, make changes in the designs, specifications or components of the Goods to improve the safety of such Goods, or if in Seller's judgment, such changes will be beneficial to their operation or use. Buyer may not make any changes in the specifications for the Goods unless Seller approves of such changes in writing, in which event Seller may impose additional charges to implement such changes.

Limited Warranty. Seller warrants to the original end-user that the Goods manufactured or provided by Seller under this Agreement shall be free of defects in material or workmanship for a period of twelve (12) months from the date of purchase, provided that the Goods are installed, used, and maintained in accordance with any instruction manual or technical guidelines provided by the Seller or supplied with the Goods, if applicable. The original end-user must give written notice to Seller of any suspected defect in the Goods prior to the expiration of the warranty period. The original end-user must also obtain a RGA from Seller prior to returning any Goods to Seller for warranty service under this paragraph. Seller will not accept any responsibility for Goods returned without a RGA. The original end-user shall be responsible for all costs and expenses associated with returning the Goods to Seller for warranty service. In the event of a defect, Seller, at its sole option, shall repair or replace the defective Goods or refund to the original end-user the purchase price for such defective Goods. Goods are not eligible for replacement or return after a period of 10 days from date of receipt. The foregoing warranty is Seller's sole obligation, and the original end-user's exclusive remedy, with regard to any defective Goods. This limited warranty does not apply to: (a) die sets, tooling, and saw blades; (b) periodic or routine maintenance and setup, (c) repair or replacement of the Goods due to normal wear and tear, (d) defects or damage to the Goods resulting from misuse, abuse, neglect, or accidents, (f) defects or damage to the Goods resulting from improper or unauthorized alterations, modifications, or changes; and (f) any Goods that has not been installed and/or maintained in accordance with the instruction manual or technical guidelines provided by Seller.

EXCLUSION OF OTHER WARRANTIES. THE FOREGOING LIMITED WARRANTY IS IN LIEU OF ALL OTHER WARRANTIES, EXPRESS OR IMPLIED. ANY AND ALL OTHER EXPRESS, STATUTORY OR IMPLIED WARRANTIES, INCLUDING BUT NOT LIMITED TO, ANY WARRANTY OF MERCHANTABILITY OR FITNESS FOR ANY PARTICULAR PURPOSE ARE EXPRESSLY DISCLAIMED. NO WARRANTY IS MADE WHICH EXTENDS BEYOND THAT WHICH IS EXPRESSLY CONTAINED HEREIN.

Limitation of Liability. IN NO EVENT SHALL SELLER BE LIABLE TO BUYER OR ANY OTHER PARTY FOR ANY INCIDENTAL, CONSEQUENTIAL OR SPECIAL DAMAGES (INCLUDING, WITHOUT LIMITATION, LOST PROFITS OR DOWN TIME) ARISING FROM OR IN MANNER CONNECTED WITH THE GOODS, ANY BREACH BY SELLER OR ITS AGENTS OF THIS AGREEMENT, OR ANY OTHER CAUSE WHATSOEVER, WHETHER BASED ON CONTRACT, TORT OR ANY OTHER THEORY OF LIABILITY. BUYER'S REMEDY WITH RESPECT TO ANY CLAIM ARISING UNDER THIS AGREEMENT IS STRICTLY LIMITED TO NO MORE THAN THE AMOUNT PAID BY THE BUYER FOR THE GOODS.



Force Majeure. Seller shall not be responsible for any delay in the delivery of, or failure to deliver, Goods due to causes beyond Seller's reasonable control including, without limitation, acts of God, acts of war or terrorism, enemy actions, hostilities, strikes, labor difficulties, embargoes, non-delivery or late delivery of materials, parts and equipment or transportation delays not caused by the fault of Seller, delays caused by civil authorities, governmental regulations or orders, fire, lightening, natural disasters or any other cause beyond Seller's reasonable control. In the event of any such delay, performance will be postponed by such length of time as may be reasonably necessary to compensate for the delay.

Installation. If Buyer purchases any Goods that require installation, Buyer shall, at its expense, make all arrangements and connections necessary to install and operate the Goods. Buyer shall install the Goods in accordance with any Seller instructions and shall indemnify Seller against any and all damages, demands, suits, causes of action, claims and expenses (including actual attorneys' fees and costs) arising directly or indirectly out of Buyer's failure to properly install the Goods.

Work By Others; Safety Devices. Unless agreed to in writing by Seller, Seller has no responsibility for labor or work performed by Buyer or others, of any nature, relating to design, manufacture, fabrication, use, installation or provision of Goods. Buyer is solely responsible for furnishing and requiring its employees and customers to use all safety devices, guards and safe operating procedures required by law and/or as set forth in manuals and instruction sheets furnished by Seller. Buyer is responsible for consulting all operator manuals, ANSI or comparable safety standards, OSHA regulations and other sources of safety standards and regulations applicable to the use and operation of the Goods.

Remedies. Each of the rights and remedies of Seller under this Agreement is cumulative and in addition to any other or further remedies provided under this Agreement or at law or equity.

Attorney's Fees. In the event legal action is necessary to recover monies due from Buyer or to enforce any provision of this Agreement, Buyer shall be liable to Seller for all costs and expenses associated therewith, including Seller's actual attorney fees and costs.

Governing Law/Venue. This Agreement shall be construed and governed under the laws of the State of Wisconsin, without application of conflict of law principles. Each party agrees that all actions or proceedings arising out of or in connection with this Agreement shall be commenced, tried, and litigated only in the state courts sitting in Manitowoc County, Wisconsin or the U.S. Federal Court for the Eastern District of Wisconsin. Each party waives any right it may have to assert the doctrine of "forum non conveniens" or to object to venue to the extent that any proceeding is brought in accordance with this section. Each party consents to and waives any objection to the exercise of personal jurisdiction over it by courts described in this section. Each party waives to the fullest extent permitted by applicable law the right to a trial by jury.

SUMMARY OF RETURN POLICY.

- 10 Day acceptance period from date of delivery. Damage claims and order discrepancies will not be accepted after this time.
- You must obtain a Baileigh issued RGA number PRIOR to returning any materials.
- Returned materials must be received at Baileigh in new condition and in original packaging.
- Altered items are not eligible for return.
- Buyer is responsible for all shipping charges.
- A 30% re-stocking fee applies to all returns.

Baileigh Industrial Holdings LLC makes every effort to ensure that our posted specifications, images, pricing and product availability are as correct and timely as possible. We apologize for any discrepancies that may occur. Baileigh Industrial Holdings LLC reserves the right to make any and all changes deemed necessary in the course of business including but not limited to pricing, product specifications, quantities, and product availability.

For Customer Service & Technical Support:

Please contact one of our knowledgeable Sales and Service team members at:
(920) 684-4990 or e-mail us at sales@baileighindustrial.com



INTRODUCTION

The quality and reliability of the components assembled on a Baileigh Industrial Holdings LLC machine guarantee near perfect functioning, free from problems, even under the most demanding working conditions. However, if a situation arises, refer to the manual first. If a solution cannot be found, contact the distributor where you purchased our product. Make sure you have the serial number and production year of the machine (stamped on the nameplate). For replacement parts refer to the assembly numbers on the parts list drawings.

Our technical staff will do their best to help you get your machine back in working order.

In this manual you will find: (when applicable)

- Safety procedures
- Correct installation guidelines
- Description of the functional parts of the machine
- Capacity charts
- Setup and start-up instructions
- Machine operation
- Scheduled maintenance
- Parts lists

GENERAL NOTES

After receiving your equipment remove the protective container. Do a complete visual inspection, and if damage is noted, **photograph it for insurance claims** and contact your carrier at once, requesting inspection. Also contact Baileigh Industrial Holdings LLC and inform them of the unexpected occurrence. Temporarily suspend installation.

Take necessary precautions while loading / unloading or moving the machine to avoid any injuries.

Your machine is designed and manufactured to work smoothly and efficiently. Following proper maintenance instructions will help ensure this. Try and use original spare parts, whenever possible, and most importantly; **DO NOT** overload the machine or make any unauthorized modifications.



Note: This symbol refers to useful information throughout the manual.



IMPORTANT

PLEASE READ THIS OPERATORS MANUAL CAREFULLY

It contains important safety information, instructions, and necessary operating procedures. The continual observance of these procedures will help increase your production and extend the life of the equipment.

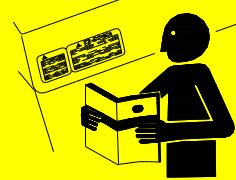

SAFETY INSTRUCTIONS

LEARN TO RECOGNIZE SAFETY INFORMATION

This is the safety alert symbol. When you see this symbol on your machine or in this manual, **BE ALERT TO THE POTENTIAL FOR PERSONAL INJURY!**



Follow recommended precautions and safe operating practices.

UNDERSTAND SIGNAL WORDS

A signal word – **DANGER**, **WARNING**, or **CAUTION** – is used with the safety alert symbol. **NOTICE**, which is not related to personal injury, is used without a symbol.

DANGER: Indicates a hazardous situation which, if not avoided, will result in death or serious injury.

WARNING: Indicates a hazardous situation which, if not avoided, could result in death or serious injury.

CAUTION: Indicates a hazardous situation which, if not avoided, could result in minor or moderate injury.

NOTICE: Indicates a situation which, if not avoided, could result in property damage.

DANGER

WARNING

CAUTION

NOTICE



SAVE THESE INSTRUCTIONS.
Refer to them often and use them to instruct others.



PROTECT EYES

Wear safety glasses or suitable eye protection when working on or around machinery.

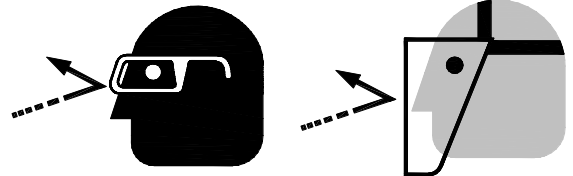

PROTECT AGAINST NOISE

Prolonged exposure to loud noise can cause impairment or loss of hearing. Wear suitable hearing protective devices such as ear muffs or earplugs to protect against objectionable or uncomfortable loud noises.

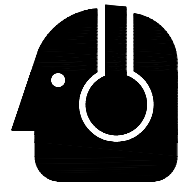

DUST HAZARD

Wear appropriate dust mask. Dust created while using machinery can cause cancer, birth defects, and long term respiratory damage. Be aware of the dust hazards associated with all types of materials.

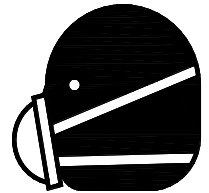

DUST PARTICLES AND IGNITION SOURCES

DO NOT operate the table saw in areas where explosion risks are high. Such areas include locations near pilot lights, open flames, or other ignition sources.

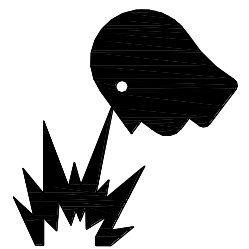

HIGH VOLTAGE

USE CAUTION IN HIGH VOLTAGE AREAS. DO NOT assume the power to be off.
FOLLOW PROPER LOCKOUT PROCEDURES.

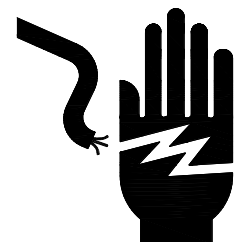



Wear Eye Protection



Read Manual



Wear Ear Protection



Wear Respiratory Protection

SAFETY PRECAUTIONS



Wood working can be dangerous if safe and proper operating procedures are not followed. As with all machinery, there are certain hazards involved with the operation of the product. Using the machine with respect and caution will considerably lessen the possibility of personal injury. However, if normal safety precautions are overlooked or ignored, personal injury to the operator may result.

Safety equipment such as guards, push sticks, hold-downs, feather boards, goggles, dust masks and hearing protection can reduce your potential for injury. But even the best guard won't make up for poor judgment, carelessness or inattention. **Always use common sense** and exercise **caution** in the workshop. If a procedure feels dangerous, don't try it.

REMEMBER: Your personal safety is your responsibility.



WARNING: FAILURE TO FOLLOW THESE RULES MAY RESULT IN SERIOUS PERSONAL INJURY

Dear Valued Customer:

- All Baileigh woodworking machines should be used only for their intended use.
- Baileigh does not recommend or endorse making any modifications or alterations to a Baileigh machine. Modifications or alterations to a machine may pose a substantial risk of injury to the operator or others and may do substantial damage to the machine.
- Any modifications or alterations to a Baileigh machine will invalidate the machine's warranty.

Please enjoy your Baileigh machine! ...Please enjoy it SAFELY!



1. **FOR YOUR OWN SAFETY, READ INSTRUCTION MANUAL BEFORE OPERATING THE MACHINE.** Learn the machine's application and limitations as well as the specific hazards.
2. **Only trained and qualified personnel can operate this machine.**
3. **Make sure guards are in place and in proper working order before operating machinery.**
4. **Keep work area clean.** Cluttered areas invite injuries.
5. **Overloading machine.** By overloading the machine, you may cause injury from flying parts. **DO NOT** exceed the specified machine capacities.
6. **Use the right tool for the job. DO NOT** attempt to force a small tool or attachment to do the work of a large industrial tool. **DO NOT** use a tool for a purpose for which it was not intended.
7. **Dress appropriate. DO NOT** wear loose fitting clothing or jewelry as they can be caught in moving machine parts. Protective clothing and steel toe shoes are recommended when using machinery. Wear a restrictive hair covering to contain long hair.
8. **Use eye and ear protection.** Always wear ISO approved impact safety goggles. Wear a full-face shield if you are producing metal filings.
9. **Do not overreach.** Maintain proper footing and balance at all times. **DO NOT** reach over or across a running machine.
10. **Stay alert.** Watch what you are doing and use common sense. **DO NOT** operate any tool or machine when you are tired.
11. **Check for damaged parts.** Before using any tool or machine, carefully check any part that appears damaged. Check for alignment and binding of moving parts that may affect proper machine operation.
12. **Observe work area conditions. DO NOT** use machines or power tools in damp or wet locations. Do not expose to rain. Keep work area well lighted. **DO NOT** use electrically powered tools in the presence of flammable gases or liquids.
13. **Keep children away.** Children must never be allowed in the work area. **DO NOT** let them handle machines, tools, or extension cords.
14. **Store idle equipment.** When not in use, tools must be stored in a dry location to inhibit rust. Always lock up tools and keep them out of reach of children.
15. **DO NOT operate machine if under the influence of alcohol or drugs.** Read warning labels on prescriptions. If there is any doubt, **DO NOT** operate the machine.
16. Turn off power before checking, cleaning, or replacing any parts.
17. Be sure all equipment is properly installed and grounded according to national, state, and local codes.
18. Inspect power and control cables periodically. Replace if damaged or bare wires are exposed. **Bare wiring can kill!**



19. **DO NOT** bypass or defeat any safety interlock systems.
20. Keep visitors a safe distance from the work area.
21. **Check** for damaged parts before using machinery. Check for binding or misaligned parts, broken parts, loose bolts, or any other conditions which may impair the machines operation. Repair or replace any damaged parts before operation.
22. **Do not remove** any warning signs.
23. **DO NOT** insert fingers or foreign objects into the dust intake ports. Keep hair, loose clothing, fingers, and all body parts away from openings and moving parts of the dust collector.
24. **DO NOT** use the dust collector without a filter bag and dust collection bag in place and properly secured.
25. **DO NOT** operate the dust collector with unused dust intake ports uncapped. **ALWAYS** cover exposed dust intake ports.
26. **PERIODICALLY INSPECT** dust and filter bags for any cuts, rips or tears. **NEVER** operate the dust collector with a damaged bag or vacuum hose.
27. The dust collector is designed for home use or light commercial duty ONLY!



IMPORTANT: Never operate the air filtration blower without the proper filters installed.



TECHNICAL SPECIFICATIONS

Motor	1/2 HP (373w) 120V, 60Hz
Power	120V, 60Hz, 8A
Motor Speed	1600 RPM
Suction Capacity	1600 CFM
Impeller Size	9.5" x 7" (241 x 178mm)
Switch	Rocker, On/Off/RF
Noise Level @ 3 Meters (9.8ft)	66dB
Overall Dimensions	40.3" x 24.8" x 21.8" (1025 x 630 x 555mm)
Shipping Dimensions	41.7" x 26.1" x 23.4" (1060 x 665 x 595mm)
N.W.	88.1lbs (40Kgs)
G.W.	97lbs (44Kgs)

TECHNICAL SUPPORT

Our technical support department can be reached at 920.684.4990 and asking for the support desk for purchased machines. Tech Support handles questions on machine setup, schematics, warranty issues, and individual parts needs: (other than die sets and blades).

For specific application needs or future machine purchases contact the Sales Department at: sales@baileigh.com, Phone: 920.684.4990, or Fax: 920.684.3944.



Note: *The photos and illustrations used in this manual are representative only and may not depict the actual color, labeling or accessories and may be intended to illustrate technique only.*



Note: *The specifications and dimensions presented here are subject to change without prior notice due to improvements of our products.*



UNPACKING AND CHECKING CONTENTS

Your Baileigh machine is shipped complete. Separate all parts from the packing material and check each item carefully. Make certain all items are accounted for before discarding any packing material.

⚠ WARNING: SUFFOCATION HAZARD! Immediately discard any plastic bags and packing materials to eliminate choking and suffocation hazards to children and animals.
If any parts are missing, **DO NOT** place the machine into service until the missing parts are obtained and installed correctly.

Cleaning

⚠ WARNING: DO NOT USE gasoline or other petroleum products to clean the machine. They have low flash points and can explode or cause fire.

⚠ CAUTION: When using cleaning solvents work in a well-ventilated area. Many cleaning solvents are toxic if inhaled.

Your machine may be shipped with a rustproof waxy coating and/or grease on the exposed unpainted metal surfaces. Fully and completely remove this protective coating using a degreaser or solvent cleaner. Moving items will need to be moved along their travel path to allow for cleaning the entire surface. For a more thorough cleaning, some parts will occasionally have to be removed. **DO NOT USE** acetone or brake cleaner as they may damage painted surfaces.

Follow manufacturer's label instructions when using any type of cleaning product. After cleaning, wipe unpainted metal surfaces with a light coating of quality oil or grease for protection.



Important: This waxy coating is **NOT** a lubricant and will cause the machine to stick and lose performance as the coating continues to dry.





INSTALLATION

IMPORTANT:

Consider the following when looking for a suitable location to place the machine:

- This unit is specifically designed to circulate and filter non-metallic dust, which is generated throughout the work area.
- Overall weight of the machine.
- Space needed for clear air flow and service access.
- Clearance from walls and other obstacles.
- Maintain an adequate working area around the machine for safety.
- Have the work area well illuminated with proper lighting.



WARNING: The mounts for this machine must be anchored to the building structure, which will support a minimum of 2 times the weight of the machine. Never mount to surfaces such as dry wall or false ceiling grids, etc.

- **CEILING:** This tool distributes a large amount of weight over a small area. Make certain that the ceiling and overhead support is capable of supporting a minimum of 2 times the weight of the machine.
- If placing the air filtration unit on a stand, verify that the machine is secured to the stand and that the stand cannot tip over.
- **WORKING CLEARANCES:** Take into consideration space around this machine to provide the air flow needed to allow for proper filtration. This unit will work best if it is located away from corners, and heating/cooling vents.
- **POWER SUPPLY PLACEMENT:** The power supply should be located close enough to the machine so that the power cord is not in an area where it would cause a tripping hazard. Be sure to observe all electrical codes if installing new circuits and/or outlets.

Placement and Positioning

Placement and Positioning planning is a key step to maximize the effectiveness of the air filter. Because each installation will be different, having different size, shape and obstructions, each placement and positioning consideration will be different.

Air flow patterns must be thought out with consideration for all obstructions to the air flow path. Think of air circulation in terms of the circular motion of the air before and after the air filter. The air exiting the filter is exhausted at a higher velocity than the air entering. Thus, exhaust air being vented inside a building will have an effect on the pattern of air circulation.



Air circulation patterns will vary depending upon which air flow speed is used and your specific shop setup.

In general, good air filter placement promotes a circular / recirculating air flow pattern.

An example of poor air circulation is where the air filter is placed too close to obstructions. This situation will cause the velocity and flow of the air to be lost and circulation and thus filtration will be diminished. Common placement and positioning issues are placing the inlet toward the center of a room with the outlet toward the wall or corner with less than 3 -4 feet (.9 – 1.2m) of clearance. This will create a turbulence on the outlet side of the filter greatly reducing its efficiency.

Placement and Position considerations:

- Examine the shop layout and try to determine the best location to hang the air filter. Air flow that is obstructed will cause poor air flow, producing unsatisfactory results. There must be a clearance of at least 3ft (.9m) from any obstructions in front and back of the unit.
- Try to place the air filter in near high dust producers or near areas where the dust is created.
- Do not place the hanging air filter where overhead items such as doors, cranes, etc. may impede the air flow, or where the air filter may impede the other device operation or movement.
- Consider the air flow of other air controlling devices such as HVAC and ceiling fans. Try to have the air filter work with the air flow of these devices.
- Plan for placement to allow the air filter to be operated, serviced, cleaned, and maintained.
- Plan for and consider the proximity to the power source. Consider the air flow of other air controlling devices such as HVAC and ceiling fans. Try to have the air filter work with the air flow of these devices.
- Ability of the remote to operate the air filtration unit.

It is very important that the hanging air filter be supported properly. Please follow these guidelines when planning where to mount the unit:

- **ONLY** hang the air filter from the mounting brackets attach to the top of the unit.
- Make sure that an electrical outlet with a properly grounded receptacle is available at the location you choose. **DO NOT** allow the power cord to become an interference or entanglement to this or other machines or people.
- The hanging air filter must be supported by structurally solid components such as joists which must be capable of supporting a minimum of 2 times the weight of the unit. **DO NOT** attach the hanging air filter to items such as but not limited to sheet rock, press board or paneling. These materials cannot support the filter, and it will fall.
- **DO NOT** use anchors such as are commonly used for mounting items to sheet rock. These anchors cannot support the weight of the filter long term and it may fall.



- Hang the air filtration unit so that the bottom is 8 – 10ft (2.4 – 3m) above the floor. This typically provides the best operation.
- Avoid hanging the filter so low and / or in a location that will cause / allow personnel to hit their head on the hanging air filter. Make sure there is enough clearance between the unit and the ground, especially important in low ceiling height locations. If possible, position the air filter in an area that has little foot traffic but still offers easy access to the switch and filters.

Filtering Performance

When used together with an efficient dust collection system, this air filter removes most fine particles up to 1 micron from the air.

At full speed, this air filter is capable of recirculating the air in a 30' x 30' x 10' room approximately 10 times an hour. If the recirculation calculation falls below 5 times per hour it is recommended to have either a larger air filtration unit or a second air filtration unit. Often, a second air filtration unit is the better answer as it will generally provide the opportunity for placement and positioning that will be complimentary to the first air filtration unit. In short, rooms with a larger volume may require two or more air filters to achieve proper filtering.

To calculate the recirculating rate for your shop space:

1. Calculate the volume of air in your shop by multiplying the length x width x height of the room. Then, divide the volume by the speed (CFM) you have chosen to operate the air filter. This will give you how many minutes it takes to recirculate the air in the room.

Example: For a room that measures 30' x 30' x 10' with this air filter running at 1600CFM, hi speed, the following calculation indicates the number of minutes to recirculate the air in the room.

$$\frac{30' \times 30' \times 10'}{1600\text{CFM}} = \frac{9000 \text{ ft}^3}{1600\text{CFM}} = 5.625 \text{ Minutes}$$

2. Once the first calculation is complete to determine the minutes to recirculate the air, the next calculation may be completed by dividing 60 minutes by the circulating time. This will give you how many times an hour the air in the room is recirculated

$$\frac{60 \text{ Min.}}{5.625 \text{ Min.}} = 10.6 \text{ Times per Hour}$$



Important: *These calculations provide results based upon best case conditions. Specific results and actual performance will vary based upon each individual installation, obstructions, motor speed, cleanliness of the filters etc.*



ASSEMBLY AND SET UP

⚠ WARNING: For your own safety, **DO NOT** connect the machine to the power source until the machine is completely assembled and you read and understand the entire instruction manual.

1. To assemble, first place the hanger (NO.3) to cabinet (NO.4) and tighten up. See FIG.1

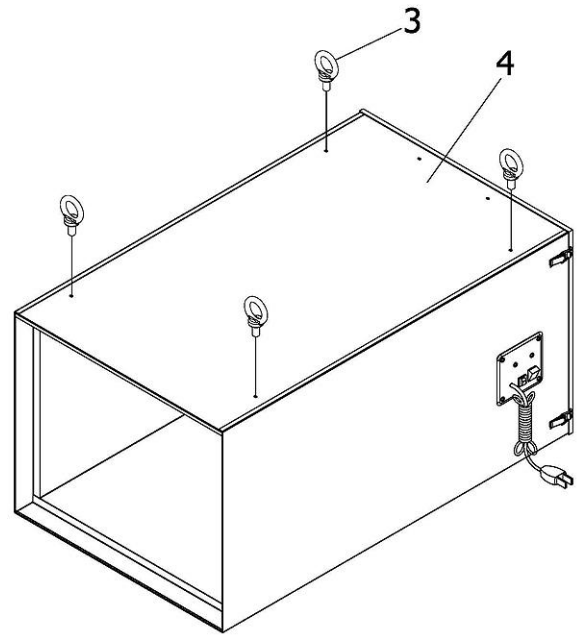

Fig.1

2. Installed the Inn-Bag Filter (NO.2) into the cabinet (NO.4). See FIG.2

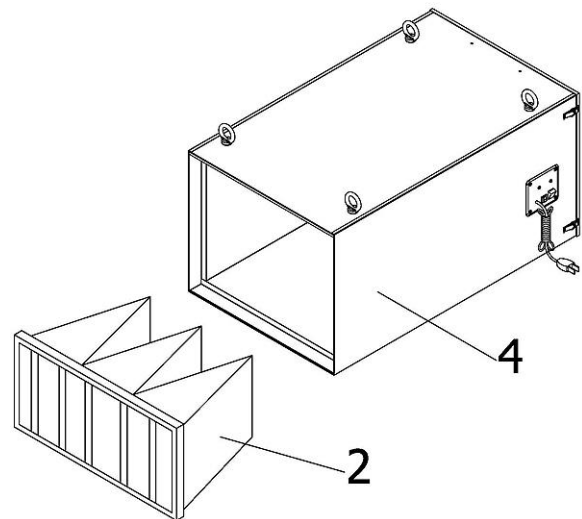

Fig.2



3. Installed the Outer Pre-Filter (NO.1) into the cabinet (NO.4). See FIG.3

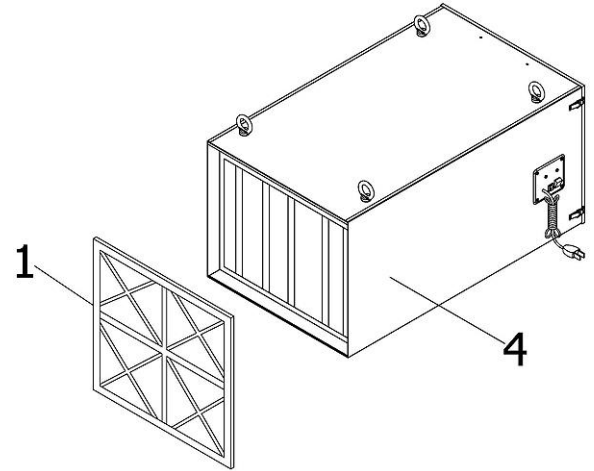

Fig.3



installed.

IMPORTANT: Never operate the air filtration blower without the proper filters



Two Person Lift. Use an assistant or lifting device to support the weight of the air filtration unit.

4. Following the Installation guidelines and the placement and positioning guidelines, install mounting hardware (customer supplied) into/onto the support structure of the building.
5. Verify that the mounting is into/onto solid components such as joists which are capable of supporting a minimum of 2 times the weight of the unit. DO NOT attach the hanging air filter to items such as but not limited to sheet rock, press board or paneling. These materials cannot support the filter, and it will fall.

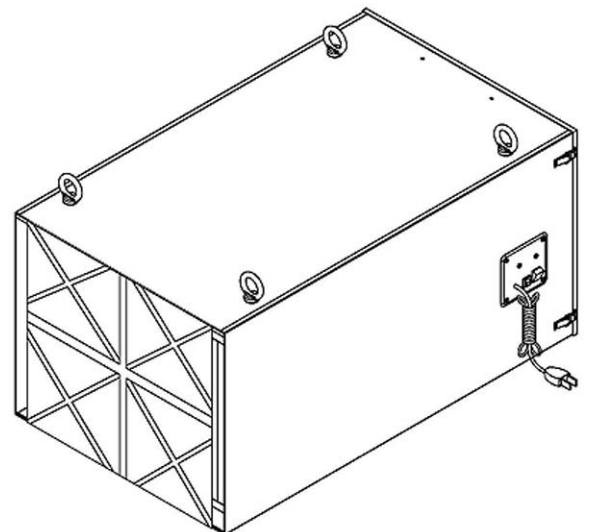



ELECTRICAL

 **CAUTION:** HAVE ELECTRICAL UTILITIES CONNECTED TO MACHINE BY A CERTIFIED ELECTRICIAN!
Check if the available power supply is the same as listed on the machine nameplate.

 **WARNING:** Make sure the grounding wire (green) is properly connected to avoid electric shock. DO NOT switch the position of the green grounding wire if any electrical plug wires are switched during hookup.

Power Specifications

Your tool is wired for 120 volts, 60Hz alternating current. Before connecting the tool to the power source, make sure the machine is cut off from power source.

Before switching on the power, you must check the voltage and frequency of the power to see if they meet with the requirement, the allowed range for the voltage is $\pm 5\%$, and for the frequency is $\pm 1\%$.

Considerations

- Observe local electrical codes when connecting the machine.
- The circuit should be protected with a time delay fuse or circuit breaker with a amperage rating slightly higher than the full load current of machine.
- A separate electrical circuit should be used for your tools. Before connecting the motor to the power line, make sure the switch is in the "OFF" position and be sure that the electric current is of the same characteristics as indicated on the tool.
- All line connections should make good contact. Running on low voltage will damage the motor.
- In the event of a malfunction or breakdown, grounding provides a path of least resistance for electric current to reduce the risk of electric shock. This tool is equipped with an electric cord having an equipment-grounding conductor and a grounding plug. The plug must be plugged into a matching outlet that is properly installed and grounded in accordance with all local codes and ordinances.

 **WARNING:** In all cases, make certain the receptacle in question is properly grounded. If you are not sure, have a qualified electrician check the receptacle.



- Improper connection of the equipment-grounding conductor can result in risk of electric shock. The conductor with insulation having an outer surface that is green with or without yellow stripes is the equipment-grounding conductor. If repair or replacement of the electric cord or plug is necessary, do not connect the equipment-grounding conductor to a live terminal.
- Check with a qualified electrician or service personnel if the grounding instructions are not completely understood, or if in doubt as to whether the tool is properly grounded.
- Repair or replace damaged or worn cord immediately.

Extension Cord Safety

Extension cord should be in good condition and meet the minimum wire gauge requirements listed below:

AMP RATING	LENGTH		
	25ft	50ft	100ft
1-12	16	16	14
13-16	14	12	12
17-20	12	12	10
21-30	10	10	No
WIRE GAUGE			

An undersized cord decreases line voltage, causing loss of power and overheating. All cords should use a ground wire and plug pin. Replace any damaged cords immediately.

Power cord connection:

1. Turn the main disconnect switch on the control panel to the OFF position.
2. Unwrap the power cord and route the cord away from the machine toward the power supply.
 - a. Route the power cord so that it will NOT become entangled in the machine in any way.
 - b. Route the cord to the power supply is a way that does NOT create an entanglement hazard.
3. Connect the power cord to the power supply and check that the power cord has not been damaged during installation.
4. When the machine is clear of any obstruction. The main power switch may be turn ON to test the operation. Turn the switch OFF when the machine is not in operation.



WIRING DIAGRAM

120V 60HZ 1~ 30A

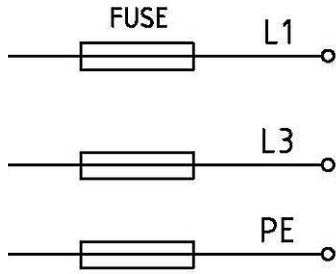

Limit of equipment

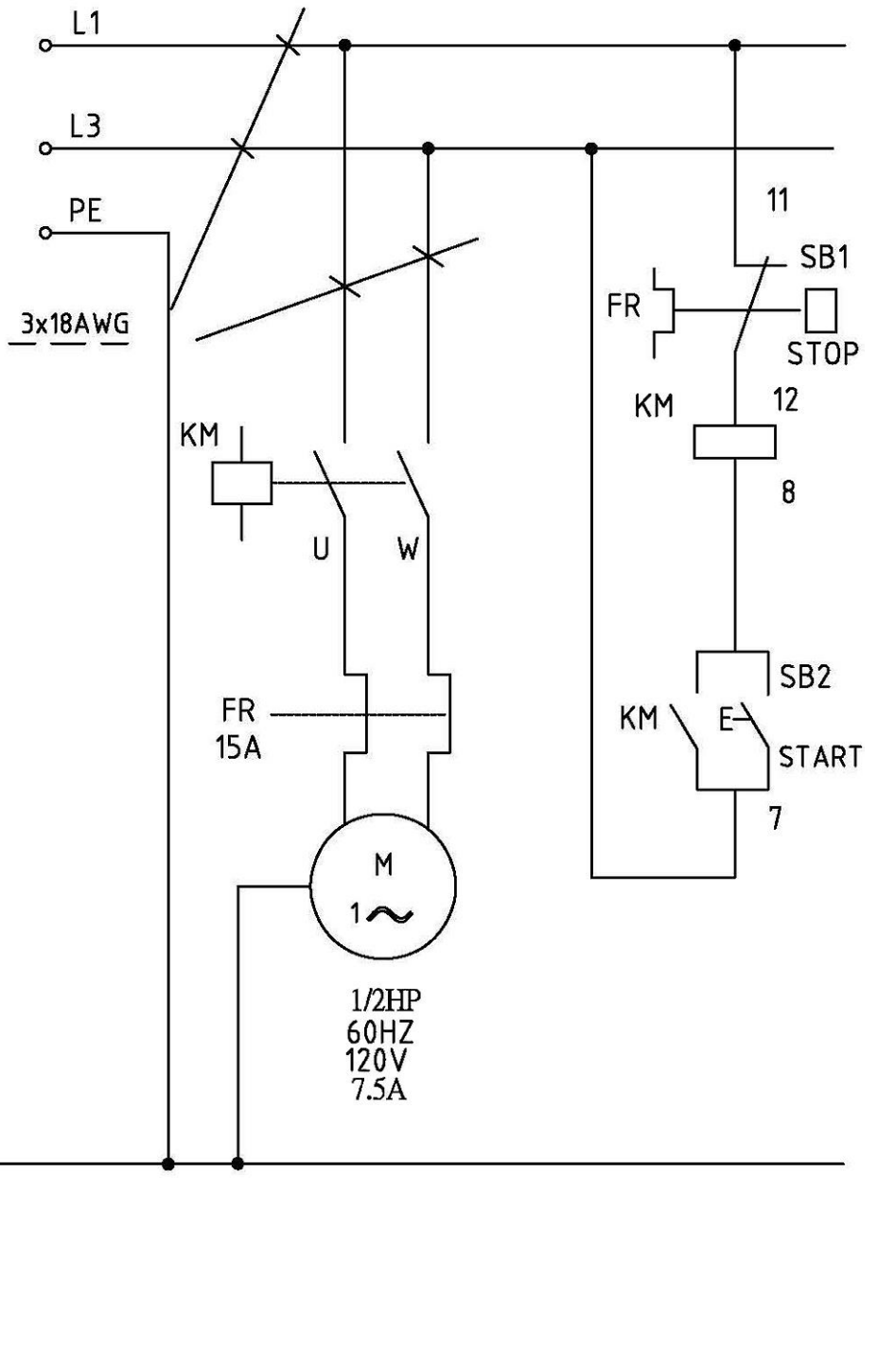



OPERATION

The control panel on the filtration unit has a three-position rocker switch.

The Off position will turn the unit Off and disable the remote control.

The On position will override the remote control and power the filtration unit On at full speed.

The unit will run until the rocker switch is turned Off.

The RF position will activate the remote control and speed and run time will be controlled by the remote.

When the air filtration unit is safely positioned on a stand or mounted to the ceiling, place the rocker On/Off/RF switch on the control panel to the desire position. RF is typical.

Remote Control Operation



Note: The switch on the filtration unit may remain in the RF position for normal daily operation. It is advised to turn the rocker switch Off during extended period of nonuse such as vacations.

The remote control has four control buttons: ON (Hour/Speed), OFF, SPEED/HOUR – (minus), SPEED/HOUR + (plus).

There are also 3 Speed LED's and 5 Hour LED's.

1. Press the On button to activate the unit. The filter will power On in at Low speed with infinite running time. The remote will be in Speed mode as well.
2. Press the Speed/Hour + (Plus) button to increase (or minus button to decrease) the blower speed.
3. Press the On button a second time to enter the Hour mode.
4. Press the Speed/Hour + (Plus) button to increase (or minus button to decrease) the time setting to the hours desired. The choices are Infinite (On until the operator turns the unit off), 2, 4, 6, or 8 hours.
5. At any time when desired, press the Off button to stop the filter.



Note: The remote requires two (2) AAA batteries. The Battery housing is located underneath the back cover.





PARTS DIAGRAM

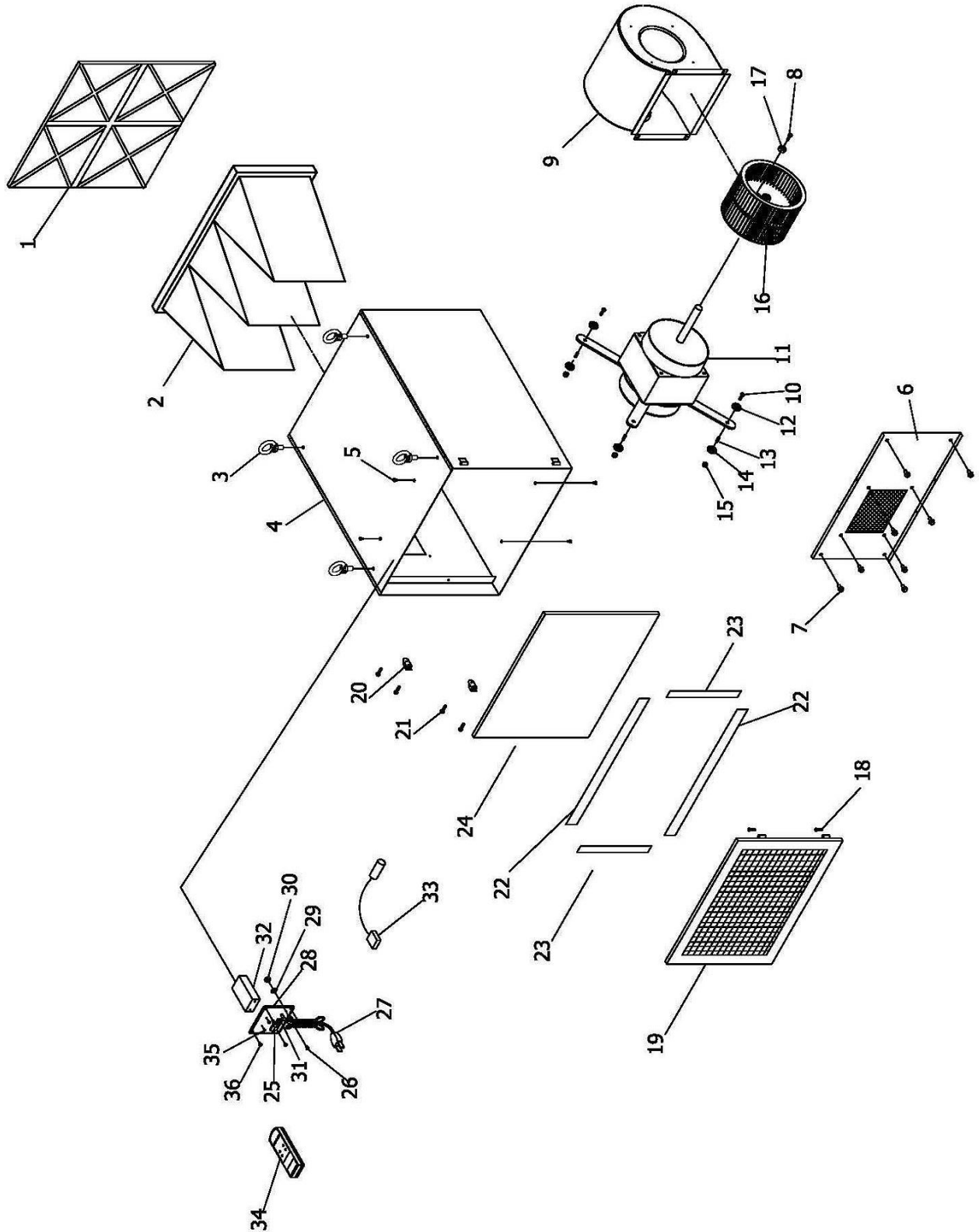



Part List

Item	Description	Specification	Qty.
AC1600-1	Outer Pre-Filter		1
AC1600-2	Inn-Bag Filter		1
AC1600-3	Hanger	1/4"	4
AC1600-4	Cabinet		1
AC1600-5	Tapping Screw	M4x12	4
AC1600-6	Front Cover		1
AC1600-7	Flange Bolt	5/16"x1/2"	8
AC1600-8	Phillips Head Hex Bolt	M8x20	1
AC1600-9	Blower		1
AC1600-10	Phillips Head Hex Bolt	1/4"x3/4"	4
AC1600-11	Motor		1
AC1600-12	Gasket		4
AC1600-13	Fix Board Ring		4
AC1600-14	Washer	1/4"x18x1.5	4
AC1600-15	Lock Nut	1/4"	4
AC1600-16	Impeller		1
AC1600-17	Nut	M8	1
AC1600-18	Hinge		2
AC1600-19	Front Cover		1
AC1600-20	Housing Clamp		2
AC1600-21	Rivet	4-2	4
AC1600-22	Velcro (Long)		2
AC1600-23	Velcro (Short)		2
AC1600-24	Filter Foam		1
AC1600-25	Circuit Breaker, 8 Amp		1
AC1600-26	Phillips Head Screw	M4x12	1
AC1600-27	Power Cord		1
AC1600-28	Switch Board		1
AC1600-29	Gear Washer	M4	1
AC1600-30	Nut	M4	1
AC1600-31	ON/OFF Switch		1
AC1600-32	IC Board		1



Item	Description	Specification	Qty.
AC1600-33	Connecting Cord		1
AC1600-34	Remote Control Bar		1
AC1600-35	Phillips Head Screw	M4x6	2
AC1600-36	Phillips Head Screw	M4x8	4



MAINTENANCE



WARNING: Make sure the electrical disconnect is OFF before working on the machine.

Maintenance should be performed on a regular basis by qualified personnel.

Always follow proper safety precautions when working on or around any machinery.

Daily Maintenance

- Do a general cleaning by removing dust and chips from the machine.
- Check and tighten any loose mounting bolts.
- Inspect the power plug and cord.
- Keep area around machine clear of debris.
- Check for any unsafe conditions and fix immediately.
- Check that all nuts and bolts are properly tightened.



Note: When cleaning chips and debris from the machine, use a brush and a shop vacuum. **DO NOT** blow off the machine with compressed air. The force of the compressed air may force chips into critical mechanisms or may inflict injury to yourself or others.

Changing Filters

Use the parts diagram and the assembly steps to assist in filter changing and replacement.

1. Disconnect the filtration unit from the power supply.
2. Release the latches on the end of the unit being serviced. (inlet or outlet end.)
3. Remove the cover.
4. Remove the outer pre-filter and then the inner bag filter from the inlet end.
5. From the outlet end, open the cover and remove the foam filter.
6. Clean the filters as needed with compressed air and if desired by washing.
7. Allow to fully dry before installing.
8. Reverse the procedure to install the cleaned or replacement filters. Verify that the filters are properly fitted into their mountings.
9. Secure the latches to close the covers and hold the filters in position.



IMPORTANT: Never operate without the proper filters installed.



NOTES



NOTES



BAILEIGH INDUSTRIAL HOLDINGS LLC
1625 DUFEK DRIVE MANITOWOC, WI 54220
PHONE: 920. 684. 4990 FAX: 920. 684. 3944
www.baileigh.com