



OPERATOR'S MANUAL

Metal Working



HORIZONTAL BAND SAW MODEL: BS-210M

Baileigh Industrial Holdings LLC
P.O. Box 531
Manitowoc, WI 54221-0531
Phone: 920.684.4990
Fax: 920.684.3944
sales@baileigh.com

REPRODUCTION OF THIS MANUAL IN ANY FORM WITHOUT WRITTEN APPROVAL OF BAILEIGH INDUSTRIAL HOLDINGS LLC IS PROHIBITED. Baileigh Industrial Holdings LLC, Inc. does not assume and hereby disclaims any liability for any damage or loss caused by an omission or error in this Operator's Manual, resulting from accident, negligence, or other occurrence.

Rev. 06/2021

© 2021 Baileigh Industrial Holdings LLC



Table of Contents

THANK YOU & WARRANTY	1
INTRODUCTION.....	3
GENERAL NOTES.....	3
SAFETY INSTRUCTIONS	4
SAFETY PRECAUTIONS	6
Dear Valued Customer:.....	6
TECHNICAL SPECIFICATIONS	9
TECHNICAL SUPPORT	9
UNPACKING AND CHECKING CONTENTS.....	10
TRANSPORTING AND LIFTING	11
INSTALLATION.....	11
Anchoring the Machine.....	12
OVERALL DIMENSIONS.....	12
GETTING TO KNOW YOUR MACHINE	13
ASSEMBLY AND SET UP	17
ELECTRICAL.....	18
Power cord connection:	19
BEFORE EACH USE	20
Whenever Saw is Running	20
BLADE CARE	21
Breaking in a Band Saw Blade	21
Metal Chip Indicators.....	21
Blade Terminology.....	22
Width of Blade	22
Length of Blade	22
Cutting and advance speed.....	23
CHOOSING A SAW BLADE	23
Blade structure	25
Blade type	25
SETS.....	26
BLADE BREAKAGE.....	27
OPERATION.....	28
Manual Operation	28
Auto Mode Operation	29
Clamping	30
MATERIAL SELECTION.....	30
MACHINE ADJUSTMENTS	31
Blade Replacement	31
Setting Blade Tension	32
Adjusting the Blade Tracking.....	32
Adjusting the Blade Guide	33
Blade Guide Bearing Adjustment.....	33
LUBRICATION AND MAINTENANCE	34



Oils for Lubricating Coolant	35
Oil Disposal	35
Coolant System Maintenance.....	35
Gearbox Maintenance	36
Storing Machine for Extended Period of Time	36
PARTS DIAGRAM AND PARTSLIST	37
Parts Diagram A	37
Parts Diagram B	38
Parts Diagram C.....	39
Parts Diagram D.....	40
Parts List A – D.....	41
LIFT ASSEMBLY PARTS DIAGRAM E	47
Lift Assembly Parts List E.....	48
ELECTRICAL SCHEMATIC.....	49
FAULT DISPLAYS	50
Error Trip Messages of Drive.....	50
Warning Messages of Drive.....	51
TROUBLESHOOTING	52



THANK YOU & WARRANTY

Thank you for your purchase of a machine from Baileigh Industrial Holdings LLC. We hope that you find it productive and useful to you for a long time to come.

Inspection & Acceptance. Buyer shall inspect all Goods within ten (10) days after receipt thereof. Buyer's payment shall constitute final acceptance of the Goods and shall act as a waiver of the Buyer's rights to inspect or reject the goods unless otherwise agreed. If Buyer rejects any merchandise, Buyer must first obtain a Returned Goods Authorization ("RGA") number before returning any goods to Seller. Goods returned without an RGA will be refused. Seller will not be responsible for any freight costs, damages to goods, or any other costs or liabilities pertaining to goods returned without a RGA. Seller shall have the right to substitute a conforming tender. Buyer will be responsible for all freight costs to and from Buyer and repackaging costs, if any, if Buyer refuses to accept shipment. If Goods are returned in unsalable condition, Buyer shall be responsible for full value of the Goods. Buyer may not return any special-order Goods. Any Goods returned hereunder shall be subject to a restocking fee equal to 30% of the invoice price.

Specifications. Seller may, at its option, make changes in the designs, specifications or components of the Goods to improve the safety of such Goods, or if in Seller's judgment, such changes will be beneficial to their operation or use. Buyer may not make any changes in the specifications for the Goods unless Seller approves of such changes in writing, in which event Seller may impose additional charges to implement such changes.

Limited Warranty. Seller warrants to the original end-user that the Goods manufactured or provided by Seller under this Agreement shall be free of defects in material or workmanship for a period of twelve (12) months from the date of purchase, provided that the Goods are installed, used, and maintained in accordance with any instruction manual or technical guidelines provided by the Seller or supplied with the Goods, if applicable. The original end-user must give written notice to Seller of any suspected defect in the Goods prior to the expiration of the warranty period. The original end-user must also obtain a RGA from Seller prior to returning any Goods to Seller for warranty service under this paragraph. Seller will not accept any responsibility for Goods returned without a RGA. The original end-user shall be responsible for all costs and expenses associated with returning the Goods to Seller for warranty service. In the event of a defect, Seller, at its sole option, shall repair or replace the defective Goods or refund to the original end-user the purchase price for such defective Goods. Goods are not eligible for replacement or return after a period of 10 days from date of receipt. The foregoing warranty is Seller's sole obligation, and the original end-user's exclusive remedy, with regard to any defective Goods. This limited warranty does not apply to: (a) die sets, tooling, and saw blades; (b) periodic or routine maintenance and setup, (c) repair or replacement of the Goods due to normal wear and tear, (d) defects or damage to the Goods resulting from misuse, abuse, neglect, or accidents, (e) defects or damage to the Goods resulting from improper or unauthorized alterations, modifications, or changes; and (f) any Goods that has not been installed and/or maintained in accordance with the instruction manual or technical guidelines provided by Seller.

EXCLUSION OF OTHER WARRANTIES. THE FOREGOING LIMITED WARRANTY IS IN LIEU OF ALL OTHER WARRANTIES, EXPRESS OR IMPLIED. ANY AND ALL OTHER EXPRESS, STATUTORY OR IMPLIED WARRANTIES, INCLUDING BUT NOT LIMITED TO, ANY WARRANTY OF MERCHANTABILITY OR FITNESS FOR ANY PARTICULAR PURPOSE ARE EXPRESSLY DISCLAIMED. NO WARRANTY IS MADE WHICH EXTENDS BEYOND THAT WHICH IS EXPRESSLY CONTAINED HEREIN.

Limitation of Liability. IN NO EVENT SHALL SELLER BE LIABLE TO BUYER OR ANY OTHER PARTY FOR ANY INCIDENTAL, CONSEQUENTIAL OR SPECIAL DAMAGES (INCLUDING, WITHOUT LIMITATION, LOST PROFITS OR DOWN TIME) ARISING FROM OR IN MANNER CONNECTED WITH THE GOODS, ANY BREACH BY SELLER OR ITS AGENTS OF THIS AGREEMENT, OR ANY OTHER CAUSE WHATSOEVER, WHETHER BASED ON CONTRACT, TORT OR ANY OTHER THEORY OF LIABILITY. BUYER'S REMEDY WITH RESPECT TO ANY CLAIM ARISING UNDER THIS AGREEMENT IS STRICTLY LIMITED TO NO MORE THAN THE AMOUNT PAID BY THE BUYER FOR THE GOODS.



Force Majeure. Seller shall not be responsible for any delay in the delivery of, or failure to deliver, Goods due to causes beyond Seller's reasonable control including, without limitation, acts of God, acts of war or terrorism, enemy actions, hostilities, strikes, labor difficulties, embargoes, non-delivery or late delivery of materials, parts and equipment or transportation delays not caused by the fault of Seller, delays caused by civil authorities, governmental regulations or orders, fire, lightning, natural disasters or any other cause beyond Seller's reasonable control. In the event of any such delay, performance will be postponed by such length of time as may be reasonably necessary to compensate for the delay.

Installation. If Buyer purchases any Goods that require installation, Buyer shall, at its expense, make all arrangements and connections necessary to install and operate the Goods. Buyer shall install the Goods in accordance with any Seller instructions and shall indemnify Seller against any and all damages, demands, suits, causes of action, claims and expenses (including actual attorneys' fees and costs) arising directly or indirectly out of Buyer's failure to properly install the Goods.

Work By Others; Safety Devices. Unless agreed to in writing by Seller, Seller has no responsibility for labor or work performed by Buyer or others, of any nature, relating to design, manufacture, fabrication, use, installation or provision of Goods. Buyer is solely responsible for furnishing and requiring its employees and customers to use all safety devices, guards and safe operating procedures required by law and/or as set forth in manuals and instruction sheets furnished by Seller. Buyer is responsible for consulting all operator manuals, ANSI or comparable safety standards, OSHA regulations and other sources of safety standards and regulations applicable to the use and operation of the Goods.

Remedies. Each of the rights and remedies of Seller under this Agreement is cumulative and in addition to any other or further remedies provided under this Agreement or at law or equity.

Attorney's Fees. In the event legal action is necessary to recover monies due from Buyer or to enforce any provision of this Agreement, Buyer shall be liable to Seller for all costs and expenses associated therewith, including Seller's actual attorney fees and costs.

Governing Law/Venue. This Agreement shall be construed and governed under the laws of the State of Wisconsin, without application of conflict of law principles. Each party agrees that all actions or proceedings arising out of or in connection with this Agreement shall be commenced, tried, and litigated only in the state courts sitting in Manitowoc County, Wisconsin or the U.S. Federal Court for the Eastern District of Wisconsin. Each party waives any right it may have to assert the doctrine of "forum non conveniens" or to object to venue to the extent that any proceeding is brought in accordance with this section. Each party consents to and waives any objection to the exercise of personal jurisdiction over it by courts described in this section. Each party waives to the fullest extent permitted by applicable law the right to a trial by jury.

Summary of Return Policy.

- 10 Day acceptance period from date of delivery. Damage claims and order discrepancies will not be accepted after this time.
- You must obtain a Baileigh issued RGA number PRIOR to returning any materials.
- Returned materials must be received at Baileigh in new condition and in original packaging.
- Altered items are not eligible for return.
- Buyer is responsible for all shipping charges.
- A 30% re-stocking fee applies to all returns.

Baileigh Industrial Holdings LLC makes every effort to ensure that our posted specifications, images, pricing and product availability are as correct and timely as possible. We apologize for any discrepancies that may occur. Baileigh Industrial Holdings LLC reserves the right to make any and all changes deemed necessary in the course of business including but not limited to pricing, product specifications, quantities, and product availability.

For Customer Service & Technical Support:

Please contact one of our knowledgeable Sales and Service team members at:
(920) 684-4990 or e-mail us at sales@baileigh.com



INTRODUCTION

The quality and reliability of the components assembled on a Baileigh Industrial Holdings LLC machine guarantee near perfect functioning, free from problems, even under the most demanding working conditions. However, if a situation arises, refer to the manual first. If a solution cannot be found, contact the distributor where you purchased our product. Make sure you have the serial number and production year of the machine (stamped on the nameplate). For replacement parts refer to the assembly numbers on the parts list drawings.

Our technical staff will do their best to help you get your machine back in working order.

In this manual you will find: (when applicable)

- Safety procedures
- Correct installation guidelines
- Description of the functional parts of the machine
- Capacity charts
- Setup and start-up instructions
- Machine operation
- Scheduled maintenance
- Parts lists

GENERAL NOTES

After receiving your equipment remove the protective container. Do a complete visual inspection, and if damage is noted, **photograph it for insurance claims** and contact your carrier at once, requesting inspection. Also contact Baileigh Industrial Holdings LLC and inform them of the unexpected occurrence. Temporarily suspend installation.

Take necessary precautions while loading / unloading or moving the machine to avoid any injuries.

Your machine is designed and manufactured to work smoothly and efficiently. Following proper maintenance instructions will help ensure this. Try and use original spare parts, whenever possible, and most importantly; **DO NOT** overload the machine or make any modifications.



Note: This symbol refers to useful information throughout the manual.



IMPORTANT

PLEASE READ THIS OPERATORS MANUAL CAREFULLY

It contains important safety information, instructions, and necessary operating procedures. The continual observance of these procedures will help increase your production and extend the life of the equipment.

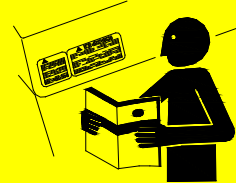

SAFETY INSTRUCTIONS

LEARN TO RECOGNIZE SAFETY INFORMATION

This is the safety alert symbol. When you see this symbol on your machine or in this manual, **BE ALERT TO THE POTENTIAL FOR PERSONAL INJURY!**



Follow recommended precautions and safe operating practices.

UNDERSTAND SIGNAL WORDS

A signal word – **DANGER**, **WARNING**, or **CAUTION** – is used with the safety alert symbol. **NOTICE**, which is not related to personal injury, is used without a symbol.

DANGER: Indicates a hazardous situation which, if not avoided, will result in death or serious injury.

WARNING: Indicates a hazardous situation which, if not avoided, could result in death or serious injury.

CAUTION: Indicates a hazardous situation which, if not avoided, could result in minor or moderate injury.

NOTICE: Indicates a situation which, if not avoided, could result in property damage.

DANGER

WARNING

CAUTION

NOTICE



SAVE THESE INSTRUCTIONS.
Refer to them often and use them to instruct others.



PROTECT EYES

Wear safety glasses or suitable eye protection when working on or around machinery.

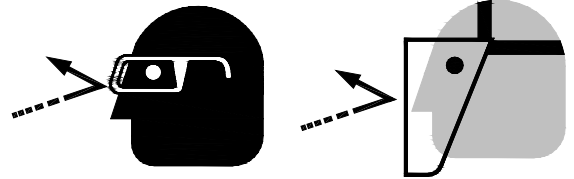

PROTECT AGAINST NOISE

Prolonged exposure to loud noise can cause impairment or loss of hearing. Wear suitable hearing protective devices such as earmuffs or earplugs to protect against objectionable or uncomfortable loud noises.

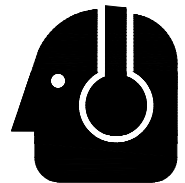

DUST HAZARD

Wear appropriate dust mask. Dust created while using machinery can cause cancer, birth defects, and long-term respiratory damage. Be aware of the dust hazards associated with all types of materials.

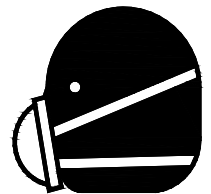

BEWARE OF CUT AND PINCH POINTS

Moving saw blade may result in loss of fingers or limb. **DO NOT** operate with guard removed. **Follow lockout/tagout procedures before servicing.**

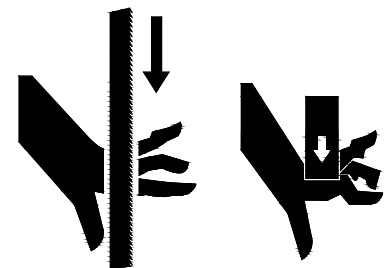

HIGH VOLTAGE

USE CAUTION IN HIGH VOLTAGE AREAS. DO NOT assume the power to be off.
FOLLOW PROPER LOCKOUT PROCEDURES.





EMERGENCY STOP BUTTON

In the event of incorrect operation or dangerous conditions, the machine can be stopped immediately by pressing the **E-STOP** button. Twist the emergency stop button clockwise (cw) to reset. Note: Resetting the E-Stop will not start the machine.

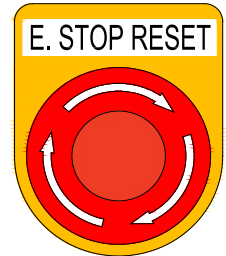

CALIFORNIA PROPOSITION 65

WARNING: Cancer and Reproductive Harm.
www.P65Warnings.ca.gov



SAFETY PRECAUTIONS



Metal working can be dangerous if safe and proper operating procedures are not followed. As with all machinery, there are certain hazards involved with the operation of the product. Using the machine with respect and caution will considerably lessen the possibility of personal injury. However, if normal safety precautions are overlooked or ignored, personal injury to the operator may result.

Safety equipment such as guards, hold-downs, safety glasses, dust masks and hearing protection can reduce your potential for injury. But even the best guard will not make up for poor judgment, carelessness or inattention. **Always use common sense** and exercise **caution** in the workshop. If a procedure feels dangerous, don't try it.

REMEMBER: Your personal safety is your responsibility.



WARNING: FAILURE TO FOLLOW THESE RULES MAY RESULT IN SERIOUS PERSONAL INJURY

Dear Valued Customer:

- All Baileigh machines should be used only for their intended use.
- Baileigh does not recommend or endorse making any modifications or alterations to a Baileigh machine. Modifications or alterations to a machine may pose a substantial risk of injury to the operator or others and may do substantial damage to the machine.
- Any modifications or alterations to a Baileigh machine will invalidate the machine's warranty.



PLEASE ENJOY YOUR BAILEIGH MACHINE!PLEASE ENJOY IT SAFELY!

1. **FOR YOUR OWN SAFETY, READ INSTRUCTION MANUAL BEFORE OPERATING THE MACHINE.** Learn the machine's application and limitations as well as the specific hazards.
2. **Only trained and qualified personnel can operate this machine.**
3. **Make sure guards are in place and in proper working order before operating machinery.**
4. **Remove any adjusting tools.** Before operating the machine, make sure any adjusting tools have been removed.
5. **Keep work area clean.** Cluttered areas invite injuries.
6. **Overloading machine.** By overloading the machine, you may cause injury from flying parts. **DO NOT** exceed the specified machine capacities.
7. **Dressing material edges.** Always chamfer and deburr all sharp edges.
8. **Do not force tool.** Your machine will do a better and safer job if used as intended. **DO NOT** use inappropriate attachments in an attempt to exceed the machine's rated capacity.
9. **Use the right tool for the job. DO NOT** attempt to force a small tool or attachment to do the work of a large industrial tool. **DO NOT** use a tool for a purpose for which it was not intended.
10. **Dress appropriately. DO NOT** wear loose fitting clothing or jewelry as they can be caught in moving machine parts. Protective clothing and steel toe shoes are recommended when using machinery. Wear a restrictive hair covering to contain long hair.
11. **Use eye protection.** Always wear ISO approved protective eye wear when operating machinery. Wear a full-face shield if you are producing metal filings. Eye wear shall be impact resistant, protective safety glasses with side shields which comply with ANSI Z87.1 specification. Use of eye wear which does not comply with ANSI Z87.1 specification could result in severe injury from breakage of eye protection.
12. **Do not overreach.** Maintain proper footing and balance at all times. **DO NOT** reach over or across a running machine.
13. **Stay alert.** Watch what you are doing and use common sense. **DO NOT** operate any tool or machine when you are tired.
14. **Check for damaged parts.** Before using any tool or machine, carefully check any part that appears damaged. Check for alignment and binding of moving parts that may affect proper machine operation.
15. **Observe work area conditions. DO NOT** use machines or power tools in damp or wet locations. Do not expose to rain. Keep work area well lighted. **DO NOT** use electrically powered tools in the presence of flammable gases or liquids.
16. **Blade adjustments and maintenance.** Always keep blades sharp and properly adjusted for optimum performance.



17. **Keep children away.** Children must never be allowed in the work area. **DO NOT** let them handle machines, tools, or extension cords.
18. Keep visitors a safe distance from the work area.
19. **Store idle equipment.** When not in use, tools must be stored in a dry location to inhibit rust. Always lock up tools and keep them out of reach of children.
20. **DO NOT operate machine if under the influence of alcohol or drugs.** Read warning labels on prescriptions. If there is any doubt, **DO NOT** operate the machine.
21. **Turn off** power before checking, cleaning, or replacing any parts.
22. Be sure **all** equipment is properly installed and grounded according to national, state, and local codes.
23. Keep **all** cords dry, free from grease and oil, and protected from sparks and hot metal.
24. Inspect power and control cables periodically. Replace if damaged or bare wires are exposed. **Bare wiring can kill!** **DO NOT** touch live electrical components or parts.
25. **DO NOT** bypass or defeat any safety interlock systems.



WARNING: This product can expose you to chemicals including titanium dioxide which is known to the State of California to cause cancer, and lead which is known to the State of California to cause cancer and birth defects or other reproductive harm.
For more information go to <http://www.p65warnings.ca.gov>.



WARNING: Some dust, fumes and gases created by power sanding, sawing, grinding, drilling, welding, and other construction activities contain chemicals known to the State of California to cause cancer and birth defects or other reproductive harm. Some examples of these chemicals are:

- lead from lead-based paint.
- crystalline silica from bricks, cement, and other masonry products.
- arsenic and chromium from chemically treated lumber.

Your risk of exposure varies, depending on how often you do this type of work. To reduce your exposure to these chemicals, work in a well-ventilated area and work with approved safety equipment, such as dust masks that are specifically designed to filter out microscopic particles.

For more information go to <http://www.p65warnings.ca.gov/> and <http://www.p65warnings.ca.gov/wood>.



TECHNICAL SPECIFICATIONS

Capacity Rectangular 90°	8.26" x 3.75" (210 x 95mm)
Capacity Round 90° / 45° / 60°	6.692" (170mm) / 4.724" (120mm) / 2.755" (70mm)
Capacity Square 90° / 45° / 60°	6.692 x 6.692" (170 x 170mm) / 4.375" x 4.375" (110 x 110mm) / 2.44" x 2.44" (60 x 60mm)
Return	Manual
Miter Adjustment	Swivel Head
Miter Angle	0 - 60°
Table Height	35.1" (892mm)
Blade Size (H x T x L)	.78" x .035" x 83.07" (20 x .9 x 2110mm)
Blade Speed (fpm)	66 – 280fpm (20 – 85mpm) Variable
Blade Guide	Carbide / Roller
Bow Descent Control	Hydraulic
Drive	Gear
Power	110V, 60hz, 1ph
Motor	1hp (.75kw), 240VAC, 3ph, 60hz, 3.5A
Shipping Weight	440lbs. (200kg)
Shipping Dimensions	60" x 44" x 48" (1524 x 1118 x 1219mm)

TECHNICAL SUPPORT

Our technical support department can be reached at 920.684.4990 and asking for the support desk for purchased machines. Tech Support handles questions on machine setup, schematics, warranty issues, and individual parts needs: (other than die sets and blades).

For specific application needs or future machine purchases contact the Sales Department at: sales@baileigh.com, Phone: 920.684.4990, or Fax: 920.684.3944.



Note: *The photos and illustrations used in this manual are representative only and may not depict the actual color, labeling or accessories and may be intended to illustrate technique only.*



Note: *The specifications and dimensions presented here are subject to change without prior notice due to improvements of our products.*



UNPACKING AND CHECKING CONTENTS

Your Baileigh machine is shipped complete. Separate all parts from the packing material and check each item carefully. Make certain all items are accounted for before discarding any packing material.

⚠ WARNING: SUFFOCATION HAZARD! Immediately discard any plastic bags and packing materials to eliminate choking and suffocation hazards to children and animals.
If any parts are missing, **DO NOT** place the machine into service until the missing parts are obtained and installed correctly.

Cleaning

⚠ WARNING: DO NOT USE gasoline or other petroleum products to clean the machine. They have low flash points and can explode or cause fire.

⚠ CAUTION: When using cleaning solvents work in a well-ventilated area. Many cleaning solvents are toxic if inhaled.

Your machine may be shipped with a rustproof waxy coating and/or grease on the exposed unpainted metal surfaces. Fully and completely remove this protective coating using a degreaser or solvent cleaner. Moving items will need to be moved along their travel path to allow for cleaning the entire surface. For a more thorough cleaning, some parts will occasionally have to be removed. **DO NOT USE** acetone or brake cleaner as they may damage painted surfaces.

Follow manufacturer's label instructions when using any type of cleaning product. After cleaning, wipe unpainted metal surfaces with a light coating of quality oil or grease for protection.



Important: This waxy coating is **NOT** a lubricant and will cause the machine to stick and lose performance as the coating continues to dry.





TRANSPORTING AND LIFTING

NOTICE: *Lifting and carrying operations should be carried out by skilled workers, such as a truck operator, crane operator, etc. If a crane is used to lift the machine, attach the lifting chain carefully, making sure the machine is well balanced.*

Follow these guidelines when lifting:

- Use proper lifting techniques when moving the saw from location to location.
- Make sure the machine is balanced, level, and securely tied or strapped to the transport vehicle or device so that all the supporting feet are taking the weight of the machine and no rocking is taking place.
- While transporting, avoid rough or jerky motion, and maintain a safe clearance zone around the transport area.

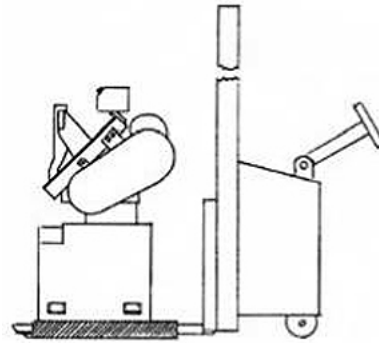

INSTALLATION

IMPORTANT:

Consider the following when looking for a suitable location to place the machine:

- Overall weight of the machine.
- Weight of material being processed.
- Sizes of material to be processed through the machine.
- Space needed for auxiliary stands, work tables, or other machinery.
- Clearance from walls and other obstacles. Maintain an adequate working area around the machine for safety.
- Have the work area well illuminated with proper lighting.
- Keep the floor free of oil and make sure it is not slippery.
- Remove scrap and waste materials regularly, and make sure the work area is free from obstructing objects.
- If long lengths of material are to be fed into the machine, make sure that they will not extend into any aisles.
- **LEVELING:** The machine should be sited on a level surface. The accuracy of any machine depends on the precise placement of it to the mounting surface. If the unit wobbles or rocks once in place, be sure to eliminate by using shims.

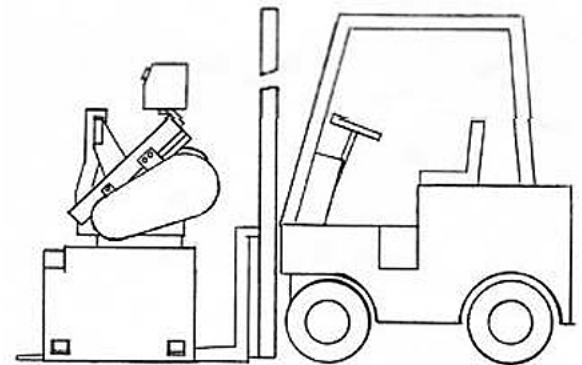



- **POWER SUPPLY PLACEMENT:** The power supply should be located close enough to the machine so that the power cord is not in an area where it would cause a tripping hazard. Be sure to observe all electrical codes if installing new circuits and/or outlets.

Anchoring the Machine

- Once positioned, anchor the machine to the floor, as shown in the diagram, using bolts and expansion plugs or sunken tie rods that connect through holes in the base of the stand.

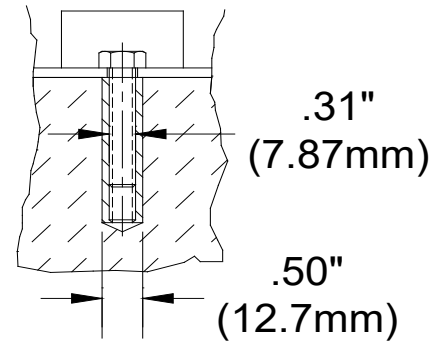

OVERALL DIMENSIONS

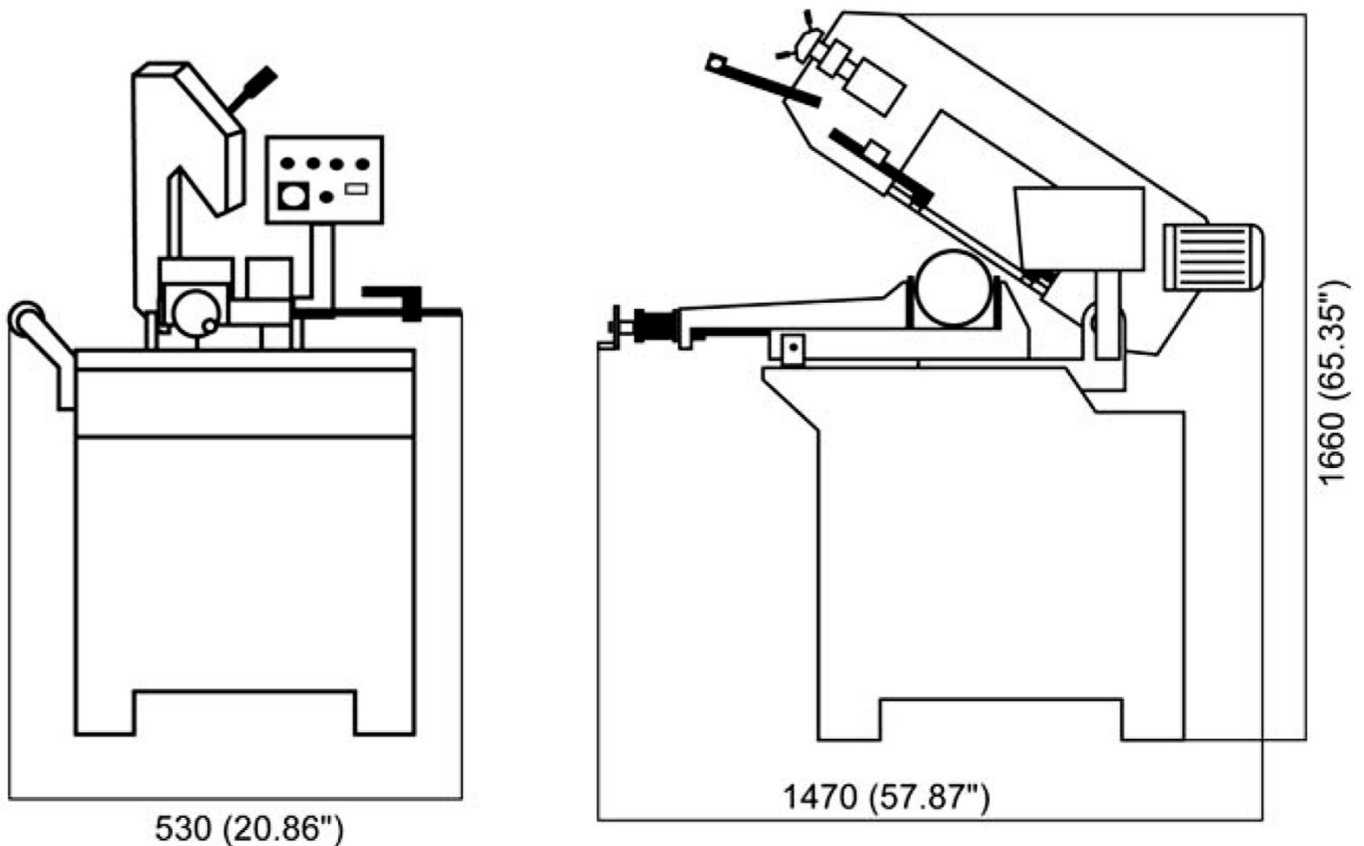



GETTING TO KNOW YOUR MACHINE





Item	Description	Function
A	Vise Hand Wheel	Turning hand-wheel opens and closes vise
B	Vise Lever	Quickly clamp and unclamp material
C	Vise	Holds front and rear jaws for clamping
D	Blade Tension Handwheel	To increase or decrease blade tension
E	Blade Tension Gauge	Reads tension in Kgs/cm ²
F	Trigger Switch	For starting saw motor in manual mode
G	Blade Guide Assembly, Front	Guides blade into the cut. Adjustable
H	Blade Guide Assembly, Rear	Guides blade out of the cut and back to the drive wheel. Adjustable.
I	Ball Valve	Used to start and stop the saw bow descent.
J	Control Box	Houses the operator controls
K	Motor/Gearbox	Drives the saw blade.
L	Balance Spring Tension Knob	Sets the tension of the bow counter balance spring
M	Micro Switch	Shuts off saw when finished cutting
N	Coolant Pump	Recirculates blade coolant
O	Stop Rod Assembly	For setting the length of cut
P	Saw Base/Stand	Supports the saw assembly
Q	Angle Indicator	Shows angular cutting degrees
R	Miter Lock Lever	Tightens and loosens table to set angles



Item	Description	Function
A	Main connect switch	Controls the power to the machine.
C	Power indicator light	Illuminates when the main power is ON.
D	Auto start cutting button	Press to start the saw blade when Mode selector is in Auto Mode
E	Emergency push button	Press to stop all saw motor function.
F	Blade Speed adjusting knob	Rotate to control the speed of the blade from 66fpm (full ccw) to 280fpm (full cw).
G	Blade Speed digital readout	Displays the approximate blade speed if Feet Per Minute.
B	Manual/Auto mode selector	Selects between Manual Mode (left position) and Auto Mode (right position).



Machine Base

After assembly, the machine base becomes the structure that supports the saw bow, the vise, the coolant pump, the bar stop, and the swing arm.



Quick Clamp Vise

Place the piece part between the vise jaws and have it rest next to the fixed vise jaw. Rotate the hand wheel (A) clockwise (cw) to close the front jaw onto the piece and tighten. Rotate the hand wheel counterclockwise (ccw) to release. Vise lever (B) can be used to quickly lock and release the piece part by allowing a small gap between the vise and part. Then rotate lever (B) counterclockwise (ccw) to lock and clockwise (cw) to release.

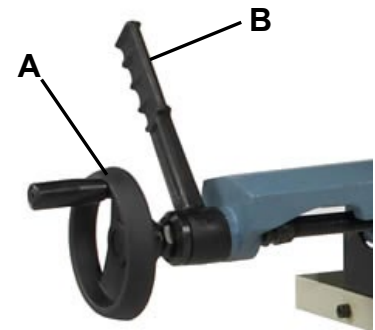

Cutting Angle Adjustment

Angles can be cut up to 60°. Unlock the rotating saw head by pushing the miter lock lever (R) to the left. Rotate the saw head to the desired angle as shown on the angle indicator (Q). Lock the saw head by pushing the lock lever (R) to the right.

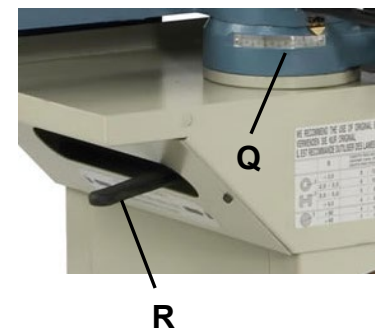

IMPORTANT: Check that the saw blade clears all parts of the vise assembly before cutting. The blade can strike parts of the assembly (especially during miter cuts) if not properly adjusted. Make sure saw bow is in a down or horizontal position when moving or mitering, to avoid tipping over machine.



ASSEMBLY AND SET UP

WARNING: For your own safety, DO NOT connect the machine to the power source until the machine is completely assembled and you read and understand the entire instruction manual.

1. Assemble the stand as shown in the Parts Identification Drawing. (Make sure all nuts and bolts are properly tightened).
2. Remove the lock lever plate (S) held on with (2) socket capscrews from the saw assembly.
3. Set the saw onto the stand and bolt together.
4. Replace the lock lever plate (S).

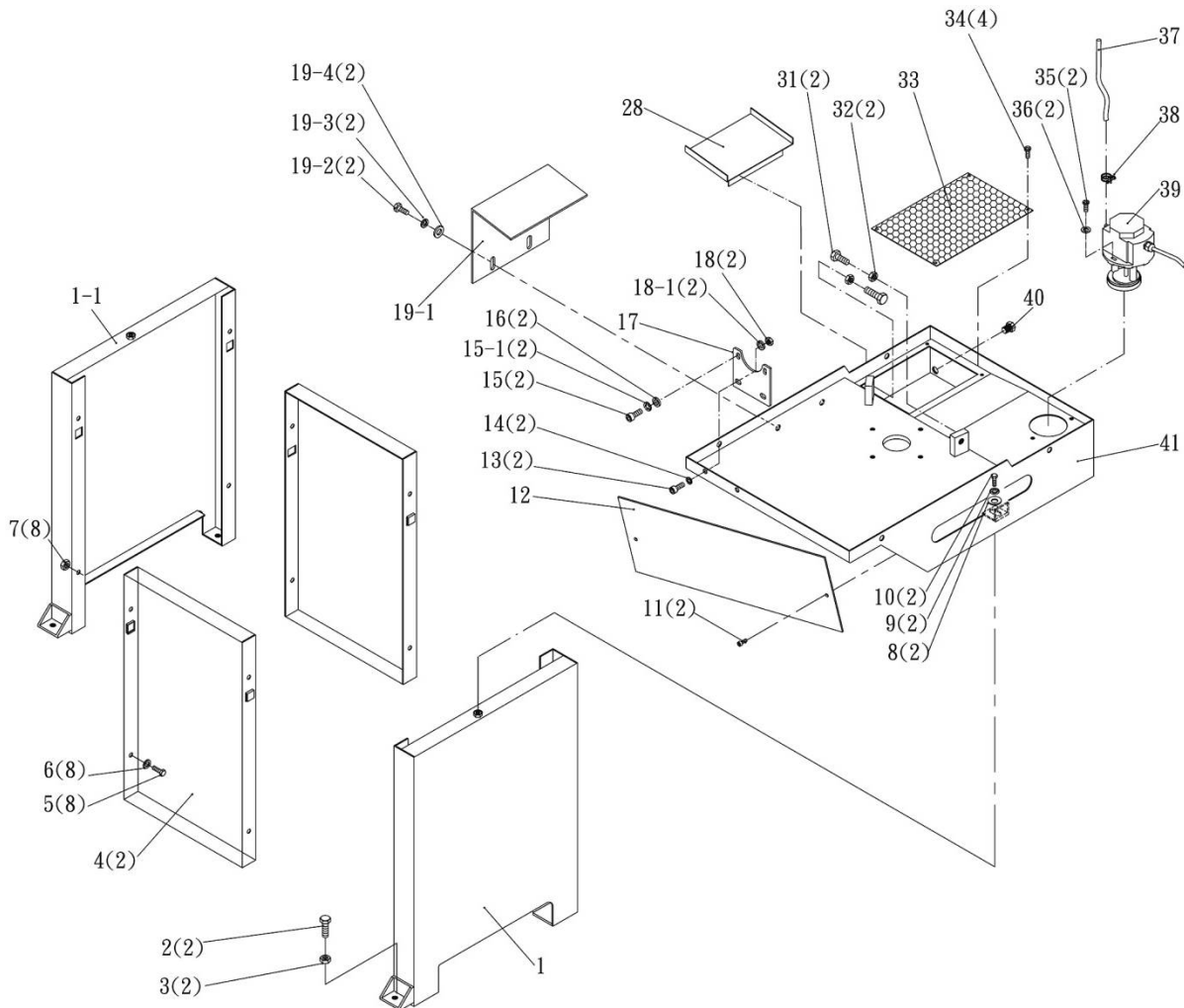



ELECTRICAL

 **CAUTION:** HAVE ELECTRICAL UTILITIES CONNECTED TO MACHINE BY A CERTIFIED ELECTRICIAN!
Check if the available power supply is the same as listed on the machine nameplate.

 **WARNING:** Make sure the grounding wire (green) is properly connected to avoid electric shock. DO NOT switch the position of the green grounding wire if any electrical plug wires are switched during hookup.

Power Specifications

Your machine is wired for 220 volts, 60hz alternating current. Before connecting the machine to the power source, make sure the power source is OFF.

Before switching on the power, you must check the voltage and frequency of the power to see if they meet with the requirement, the allowed range for the voltage is $\pm 5\%$, and for the frequency is $\pm 1\%$.

Considerations

- Observe local electrical codes when connecting the machine.
- The circuit should be protected with a time delay fuse or circuit breaker with an amperage rating slightly higher than the full load current of machine.
- A separate electrical circuit should be used for your machines. Before connecting the motor to the power line, make sure the switch is in the "OFF" position and be sure that the electric current is of the same characteristics as indicated on the machine.
- All line connections should make good contact. Running on low voltage will damage the motor.
- In the event of a malfunction or breakdown, grounding provides a path of least resistance for electric current to reduce the risk of electric shock. This machine is equipped with an electric cord having an equipment-grounding conductor and a grounding plug. The plug must be plugged into a matching outlet that is properly installed and grounded in accordance with all local codes and ordinances.

 **WARNING:** In all cases, make certain the receptacle in question is properly grounded. If you are not sure, have a qualified electrician check the receptacle.



- Improper connection of the equipment-grounding conductor can result in risk of electric shock. The conductor with insulation having an outer surface that is green with or without yellow stripes is the equipment-grounding conductor. If repair or replacement of the electric cord or plug is necessary, do not connect the equipment-grounding conductor to a live terminal.
- Check with qualified electrician or service personnel if the grounding instructions are not completely understood, or if in doubt as to whether the machine is properly grounded.
- Repair or replace damaged or worn cord immediately.

Extension Cord Safety

Extension cord should be in good condition and meet the minimum wire gauge requirements listed below:

AMP RATING	LENGTH		
	25ft	50ft	100ft
0-6	16	16	16
7-10	16	16	14
11-12	16	16	14
13-16	14	12	12
17-20	12	12	10
21-30	10	10	No
WIRE GAUGE			

An undersized cord decreases line voltage, causing loss of power and overheating. All cords should use a ground wire and plug pin. Replace any damaged cords immediately.

Power cord connection:

1. Turn the main disconnect switch on the control panel to the OFF position.
2. Unwrap the power cord and route the cord away from the table toward the power supply.
 - a. Route the power cord so that it will NOT become entangled in the saw bow, saw blade, or counterbalance assembly in any way.
 - b. Route the cord to the power supply is a way that Does NOT create a trip hazard.
3. Connect the power cord to the power supply and check that the power cord has not been damaged during installation.
4. When the saw blade is clear of any obstruction and raised up off of the limit switch. The main disconnect may be turn ON to test the saw operation. Turn the main disconnect to OFF when the saw is not in operation.



BEFORE EACH USE

- For dusty operations, wear a face shield along with safety goggles.
- It is important to choose the right blade for the material and the type of cutting you plan to do. This saw is equipped with a bi-metallic blade which can be used to cut stainless steel, steel, iron, brass, aluminum, wood, plastic.
- Make sure the direction of rotation arrow on the blade matches the direction arrow on the saw. The blade teeth should always point downward at the front of the saw.
- Make sure the blade is sharp, undamaged and properly aligned. With the saw unplugged, push the power-head all the way down. Rotate the blade by hand checking for clearance. If the blade hits anything, make the adjustments shown in the Maintaining Maximum Cutting Capacity section.
- Never cut freehand.
- Make sure the cut-off piece can move sideways after it is cut off. Otherwise, it could get wedged against the blade and thrown violently.
- Never turn the saw "ON" before clearing everything except the work piece beneath the blade.
- Never put lubricants on the blade while it is spinning.

Whenever Saw is Running

- Never confine the piece being cut out.
- Never hold it, clamp it, touch it, or use length stops against it. It must be free to move sideways. If confined, it could get wedged against the blade and thrown violently.
- Avoid awkward hand positions where a sudden slip could cause a hand to move into the blade.
- Let the blade reach full speed before cutting.
- Feed the saw into the work piece only fast enough to let the blade cut without bogging down or binding.
- Before freeing jammed material, turn the switch off and unplug the saw. Wait for all moving parts to stop.
- After finishing a cut, keep holding the saw bow down, release the switch, and wait for all moving parts to stop before moving your hands.



BLADE CARE

The bandsaw blade is subjected to a tremendous amount of strain. Make sure to always use the appropriate feed rate for the type material you are cutting.

Be sure to select a blade of the proper width, style, and pitch that will produce the best cut in your material. Choosing the wrong blade can produce excess heat that can adversely affect the life of the blade.

A clean blade performs much better than one that is dirty. Blades that are gummed up and dirty offer more resistance when cutting through the material. This in turn creates unnecessary heat in the blade.

Breaking in a Band Saw Blade

Sharp cutting edges with extremely small edge radii are required for high cutting capacity. To achieve the optimal tool life we recommend breaking-in the blade accordingly. The correct cutting speed is determined by the material being cut and its dimensions. It is very important that the new blade is first used with only 50% of the determined feed rate. This will avoid micro-breakages of the blade because of too large chip thicknesses. New band saw blades may tend toward vibrations and vibration sounds.

In this case a slight reduction of the cutting speed is helpful. With small workpiece dimensions approximately 300cm² of the material should be cut for breaking-in. If large work piece dimensions are to be cut we recommend a breaking-in period of about 15 minutes. After breaking-in you may slowly increase the feed rate up to the determined value.

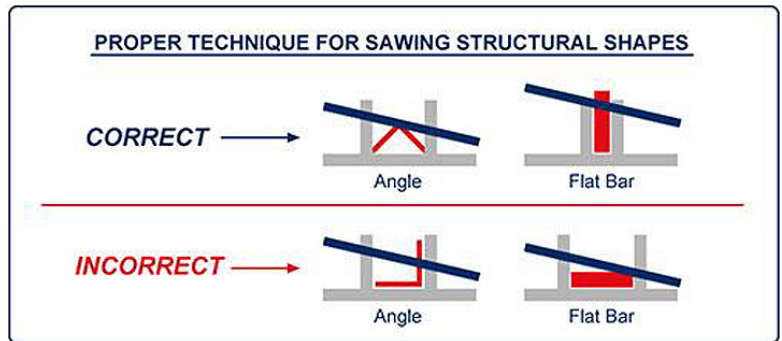

Metal Chip Indicators

Chips are the best indicator of correct material feed force. Monitor chip information and adjust feed accordingly.

- Thin or Powdered Chips – increase feed rate or reduce saw speed
- Burned Chips – reduce feed rate and / or saw speed
- Curly Silvery and Warm Chips – optimum feed rate and saw speed



Blade Terminology

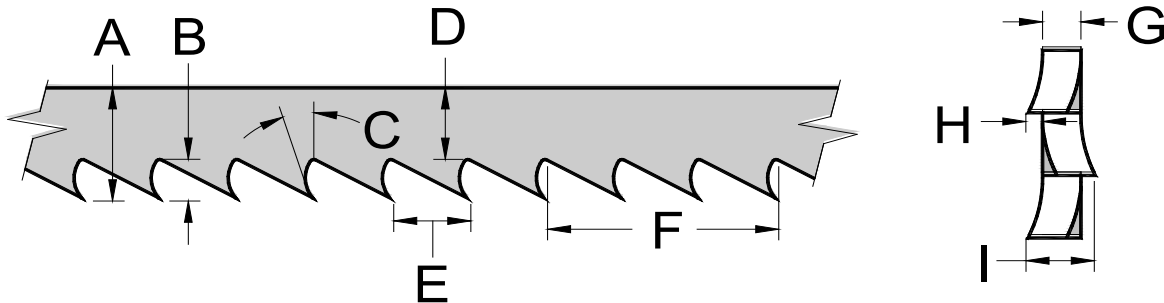

A	BLADE WIDTH	The widest part of the blade measured from the back edge of the blade to the tip of the tooth.
B	GULLET DEPTH	The distance from the tooth tip to the bottom of the curved area.
C	TOOTH RAKE	The angle of the tooth face from a line perpendicular to the length of the blade.
D	BLADE BACK	The distance between the back edge of the blade and the bottom of the gullet.
E	TOOTH PITCH	The distance between tooth tips.
F	TPI	The number of teeth per inch when measured from gullet to gullet.
G	GAUGE	The thickness of the blade.
H	TOOTH SET	The distance a tooth is bent from the blade.
I	KERF	The width of material that is removed by the blade when cutting.

Width of Blade

The blade width determines the largest and the smallest curve that can be cut. Usually the wider a blade is, the more accurate and straighter it will cut.

Length of Blade

The length of the band saw blade can be measured with a tape measure at it's circumference or by the formula below:

$$\text{Blade Length} = (2 \times A) + (3.14 \times B)$$

A = the distance in inches between the band saw pulley centers (when the upper pulley is midway in its adjustment range).

B = the band saw pulley diameter.



Cutting and advance speed

The cutting speed (m/min) and the advance speed (cm²/min = area traveled by the disk teeth when removing shavings) are limited by the development of heat close to the tips of the teeth.

- The cutting speed is subordinate to the resistance of the material ($R = N/mm^2$), to its hardness (HRC) and to the dimensions of the widest section.
- Too high an advance speed (= lowering of the saw frame) tends to cause the disk to deviate from the ideal cutting path, producing non rectilinear cuts on both the vertical and the horizontal plane.

The best combination of these two parameters can be seen directly examining the chips.

Long spiral-shaped chips indicate ideal cutting.

Very fine or pulverized chips indicate lack of feed and/or cutting pressure.

Thick and/or blue chips indicate overload of the blade.

CHOOSING A SAW BLADE

Baileigh Industrial offers a wide selection of tooth styles for various cutting applications. Please phone Baileigh Industrial to have one of our technicians assist you in selecting the proper band saw blade for your cutting applications.

A general purpose blade is furnished with this band saw.

To achieve a quality, economical, and efficient saw cut, the following points must be taken into consideration:

- Type of material being cut (ferrous or non ferrous)
- Material hardness and physical dimensions
- Blade descent rate
- Longitudinal speed of blade
- Blade tooth profile

Choose a tooth pitch that is suitable for the workpiece. Thin walled profiles, including tubes and pipes require close tothing. At least 3-6 teeth should be in contact with the material while cutting. Large solid or transverse sections require widely spaced tothing to allow for greater volume of chips and better tooth penetration. Soft materials such as plastics, light alloys, mild bronze, Teflon, etc. require widely spaced tothing to avoid clogging.



S	Outer Diameter of the Tube (inch) / Tooth pitch																
	0.787	1.574	2.362	3.15	4	4.724	6	7.873	11.811	15.75	19.685	23.621	27.5	31.5	35.5	39.5	59
0.079	14	14	14	14	14	14	10-14tpi	10-14tpi	8-12tpi	8-12tpi	6-10tpi	6-10tpi	5-8tpi	5-8tpi	5-8tpi	5-8tpi	5-8tpi
0.118	14	14	10-14tpi	10-14tpi	10-14tpi	10-14tpi	8-12tpi	8-12tpi	8-12tpi	5-8tpi	4-6tpi	4-6tpi	4-6tpi	4-6tpi	4-6tpi	4-6tpi	4-6tpi
0.157	14	14	10-14tpi	10-14tpi	8-12tpi	8-12tpi	8-12tpi	6-10tpi	5-8tpi	5-8tpi	4-6tpi	4-6tpi	4-6tpi	4-6tpi	4-6tpi	4-6tpi	4-6tpi
0.197	14	10-14tpi	10-14tpi	10-14tpi	8-12tpi	8-12tpi	8-12tpi	8-12tpi	5-8tpi	5-8tpi	4-6tpi	4-6tpi	4-6tpi	4-6tpi	3-4tpi	3-4tpi	3-4tpi
0.236	14	10-14tpi	10-14tpi	8-12tpi	8-12tpi	8-12tpi	8-12tpi	5-8tpi	5-8tpi	4-6tpi	4-6tpi	4-6tpi	3-4tpi	3-4tpi	3-4tpi	3-4tpi	3-4tpi
0.315	14	10-14tpi	8-12tpi	8-12tpi	8-12tpi	6-10tpi	6-10tpi	4-6tpi	4-6tpi	4-6tpi	4-6tpi	3-4tpi	3-4tpi	3-4tpi	3-4tpi	2-3tpi	2-3tpi
0.394		8-12tpi	6-10tpi	6-10tpi	6-10tpi	5-8tpi	5-8tpi	4-6tpi	4-6tpi	4-6tpi	3-4tpi	3-4tpi	3-4tpi	3-4tpi	2-3tpi	2-3tpi	2-3tpi
0.472		8-12tpi	6-10tpi	6-10tpi	5-8tpi	5-8tpi	4-6tpi	4-6tpi	4-6tpi	3-4tpi	3-4tpi	2-3tpi	2-3tpi	2-3tpi	2-3tpi	2-3tpi	2-3tpi
0.591		8-12tpi	6-10tpi	5-8tpi	5-8tpi	4-6tpi	4-6tpi	4-6tpi	3-4tpi	3-4tpi	2-3tpi	2-3tpi	2-3tpi	2-3tpi	2-3tpi	2-3tpi	2-3tpi
0.787			6-10tpi	5-8tpi	4-6tpi	4-6tpi	4-6tpi	3-4tpi	3-4tpi	2-3tpi	2-3tpi	2-3tpi	2-3tpi	2-3tpi	2-3tpi	2-3tpi	2-3tpi
1.181				4-6tpi	4-6tpi	3-4tpi	3-4tpi	3-4tpi	2-3tpi	2-3tpi	2-3tpi	2-3tpi	2-3tpi	2-3tpi	2-3tpi	2-3tpi	2-3tpi
2						3-4tpi	3-4tpi	2-3tpi	2-3tpi	2-3tpi	2-3tpi	2-3tpi	2-3tpi	2-3tpi	1.4-2tpi	1.4-2tpi	1.4-2tpi
3								2-3tpi	2-3tpi	2-3tpi	2-3tpi	2-3tpi	1.4-2tpi	1.4-2tpi	1.4-2tpi	1.4-2tpi	1.4-2tpi
4									2-3tpi	2-3tpi	1.4-2tpi	1.4-2tpi	1.4-2tpi	1.4-2tpi	1.4-2tpi	1.4-2tpi	1.4-2tpi
6										2-3tpi	1.4-2tpi	1.4-2tpi	1.4-2tpi	1.4-2tpi	1.4-2tpi	1.4-2tpi	1.4-2tpi
7.873											1.4-2tpi	1.4-2tpi	1.4-2tpi	1.4-2tpi	1.4-2tpi	1.4-2tpi	1.4-2tpi
9.842											1.4-2tpi	1.4-2tpi	1.4-2tpi	1.4-2tpi	1.4-2tpi	1.4-2tpi	1.4-2tpi
11.81												1.4-2tpi	1.4-2tpi	1.4-2tpi	1.4-2tpi	1.4-2tpi	1.4-2tpi
13.778													1-1.4tpi	1-1.4tpi	1-1.4tpi	1-1.4tpi	1-1.4tpi
15.747													1-1.4tpi	1-1.4tpi	1-1.4tpi	1-1.4tpi	1-1.4tpi
17.716													1-1.4tpi	1-1.4tpi	1-1.4tpi	1-1.4tpi	1-1.4tpi
19.685																	

S= Wall Thickness
 If you have to cut two or more tubes lying side by side please use this table in consideration of the double wall thickness (s).

Blade structure

Bi-metal blades are the most commonly used. They consist of a silicon-steel blade backing by a laser welded high speed steel (HSS) cutting edge. The type of stocks are classified in M2, M42, M51 and differ from each other because of their major hardness due to the increasing percentage of Cobalt (Cc) and molybdenum (Mo) contained in the metal alloy.

Blade type

They differ essentially in their constructive characteristics, such as:

- Shape and cutting angle of tooth
- Pitch
- Set

Shape and angle of tooth

REGULAR TOOTH: 0° rake and constant pitch.



Most common form for transversal or inclined cutting of solid small and average cross-sections or pipes, in laminated mild steel and gray iron or general metal.

POSITIVE RAKE TOOTH: $9^\circ - 10^\circ$ positive rake and constant pitch.



Particular use for crosswise or inclined cuts in solid sections or large pipes, but above all harder materials (highly alloyed and stainless steels, special bronze and forge pig iron).

COMBO TOOTH: pitch varies between teeth and consequently varying teeth size and varying gullet depths. Pitch varies between teeth, which ensures a smoother, quieter cut and longer blade life owing to the lack of vibration.

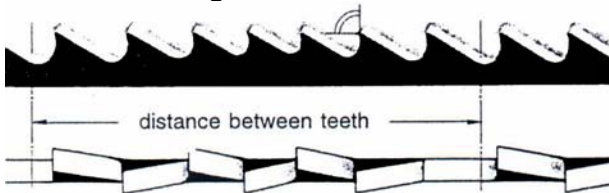

Another advantage offered in the use of this type of blade in the fact that with an only blade it is possible to cut a wide range of different materials in size and type.



COMBO TOOTH: 9° - 10° positive rake.

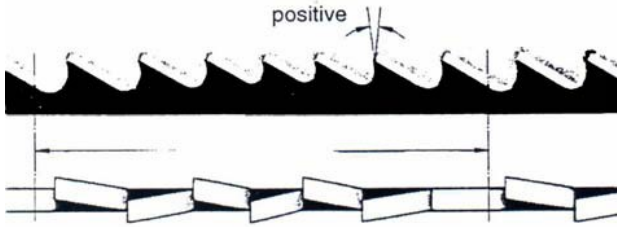

This type of blade is the most suitable for the cutting of section bars and large and thick pipes as well as for the cutting of solid bars at maximum machine capacity. Available pitches: 3-4/4-6.

SETS

Saw teeth bent out of the plane of the saw body, resulting in a wide cut in the workpiece.

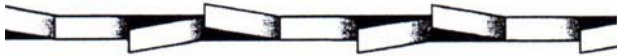

REGULAR OR RAKER SET: Cutting teeth right and left, alternated by a straight tooth.

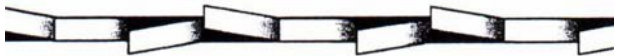

Of general use for materials with dimensions superior to 5 mm. Used for the cutting of steel, castings and hard nonferrous materials.

WAVY SET: Set in smooth waves.



This set is associated with very fine teeth and it is mainly used for the cutting of pipes and thin section bars (from 1 to 3 mm).

ALTERNATE SET (IN GROUPS): Groups of cutting teeth right and left, alternated by a straight tooth.



This set is associated with very fine teeth and it is used for extremely thin materials (less than 1mm).

ALTERNATE SET (INDIVIDUAL TEETH): Cutting teeth right and left.



This set is used for the cutting of nonferrous soft materials, plastics and wood.



BLADE BREAKAGE

In some cases blade breakage is unavoidable due to the stresses that are imparted on the blade. Avoidable breakage is often the result of poor care, or poor operator judgment when it comes to adjusting or mounting the blade or blade guides.

Listed below are some of the more common reasons for blade breakage.

- Top blade guide assembly is set too high above the piece part.
- The blade is tensioned incorrectly.
- Piece part is fed into the blade too quickly.
- Blade teeth are dull or broken.
- Blade is not properly aligned with the guides.
- Forcing a large width blade to cut a small radius.
- Using a blade with an improperly finished weld joint.
- Allowing the blade to run when not in use. (**NEVER** leave an unattended blade running.)



OPERATION

⚠ CAUTION: Always wear proper eye protection with side shields, safety footwear, and leather gloves to protect from burrs and sharp edges. **NEVER** operate saw without blade guards in place.

Manual Operation

1. Close the handle on the hydraulic ball valve (I) by turning it counterclockwise (ccw).
2. Turn the flow control knob (AH) clockwise (cw) to shut off the hydraulic flow. This will prevent the saw bow from dropping when the ball valve is opened.
3. Reduce the bow weight. Rotate the wing nut (AI) clockwise (cw) to increase the tension on the spring.
4. Load piece part and clamp securely.
5. Turn the main switch (A) to "ON". Check to see that the indicator light (B) is lit.
6. Set the blade speed with control knob (E).
7. Set switch (G) to manual mode for trigger operation.
8. While firmly holding the control handle of the saw bow, open ball valve (I) clockwise (cw).
9. Fully open the flow control knob (AH) counterclockwise (ccw).
10. Squeeze the start trigger to energize the blade motor and lower saw bow to begin cutting.
11. When saw bow reaches bottom limit, the micro switch (M) is actuated and shuts off the saw motor.
12. Return the saw bow to its start position and close ball valve (I).
13. Unclamp and reset the piece part to continue the next cutting cycle.

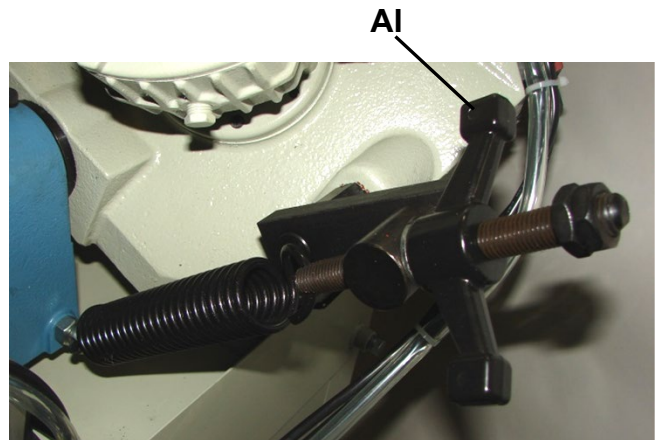



In the event of incorrect operation or dangerous condition, press the **E-STOP** button (D) to immediately shut off all functions of the saw. Twist the emergency stop button clockwise (cw) to reset.



Note: Resetting the E-STOP button will not start the machine.

Auto Mode Operation

1. Close the handle on the hydraulic ball valve (I) by turning it counterclockwise (ccw).
2. Turn the flow control knob (AH) clockwise (cw) to shut off the hydraulic flow. This will prevent the saw bow from dropping when the ball valve is opened.
3. Increase the bow weight. Rotate the wing nut (AI) counterclockwise (ccw) to decrease the tension on the spring.
4. Load piece part and clamp securely.
5. Turn the main switch (A) to "ON". Check to see that indicator light (B) is lit.
6. Set the blade speed with control knob (E).
7. Set switch (G) clockwise (cw) to auto mode for hydraulic cylinder operation.
8. Press the green start button (C). The saw motor and the coolant pump motor should both start.
9. Open the ball valve (I) clockwise (cw).
10. Turn the flow control knob (AH) clockwise (cw) to slow down the descent or counterclockwise (ccw) to speed it up.
11. When saw bow reaches bottom limit, micro-switch (M) is actuated and shuts off the saw and pump motors.
12. Grasp the control handle and lift the saw bow to a height slightly above the piece part to minimize the next cut entry time.
13. Close ball valve (I).
14. Unclamp and reset the piece part to continue the next cutting cycle.

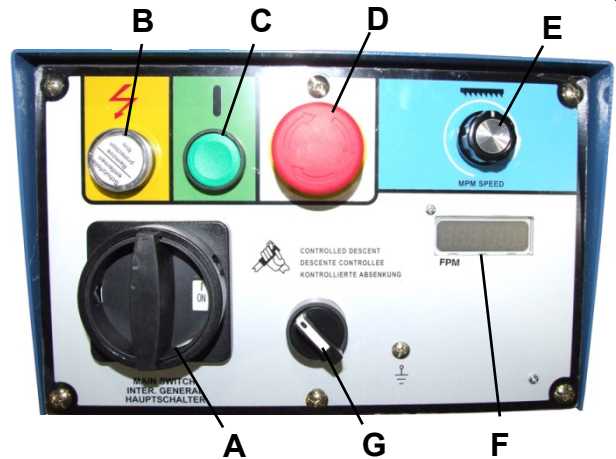



Clamping

These examples below show ways to clamp a variety of cross sections. Always keep in mind the cutting capacity of the saw to achieve efficient saw cuts and long blade life. Do not use blades of a size different from that shown in the technical specification chart.

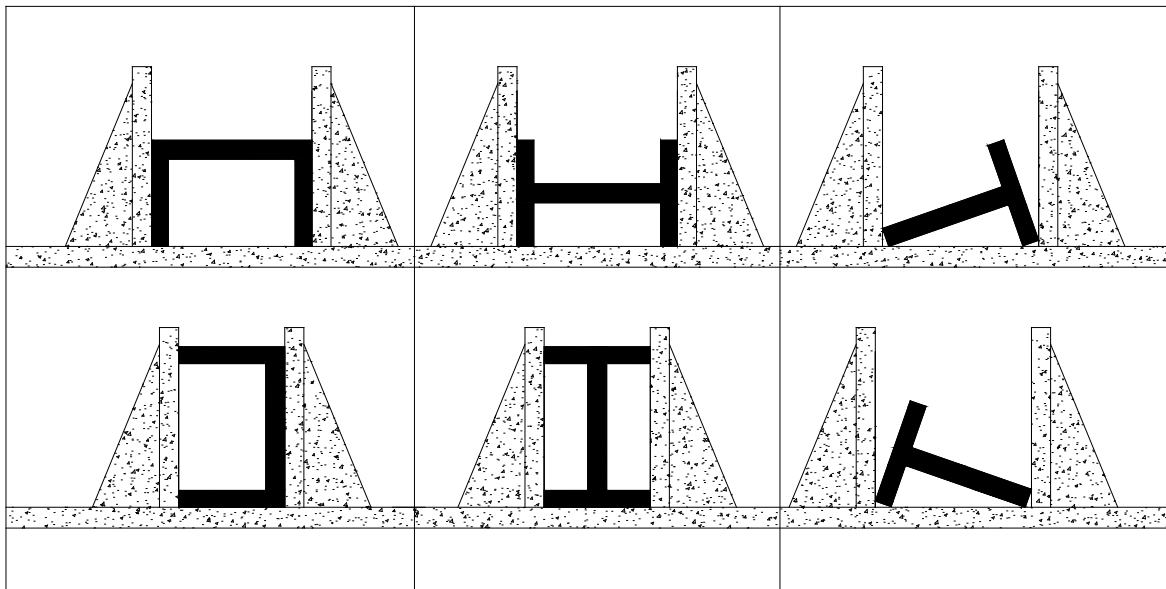

MATERIAL SELECTION

⚠ CAUTION: It must be determined by the customer that materials being processed through the machine are NOT potentially hazardous to operator or personnel working nearby.

When selecting materials keep these instructions in mind:

- Material must be clean and dry. (without oil)
- Material should have a smooth surface so it processes easily.
- Dimensional properties of material must be consistent and not exceed the machine capacity values.
- Chemical structure of material must be consistent.
- Buy certificated steel from the same vendor when possible.



MACHINE ADJUSTMENTS



WARNING: Make sure the electrical disconnect is OFF before working on the machine.
Always follow proper safety precautions when working on or around any machinery.

Blade Replacement

When replacing the saw blade: Wear gloves when handling the saw blade.

1. Raise the saw bow and fully close the ball valve.
2. Remove the front blade guard (T) and the (4) knobs (U) holding on the main blade guard.
(Carefully pull out the tongue from the safety interlock switch (V).
3. Loosen the saw blade with the tension hand wheel (D) and remove it from the flywheels and the blade guide blocks.
4. Assemble the new blade by placing it first between the guide blocks and then on the face of the flywheels. (note blade direction)
5. Tension the blade, making sure it seats properly on the flywheels.
6. Reassemble the front blade guide (T) and the main blade guard (W), making sure the switch tongue engages the switch or the saw will not start.

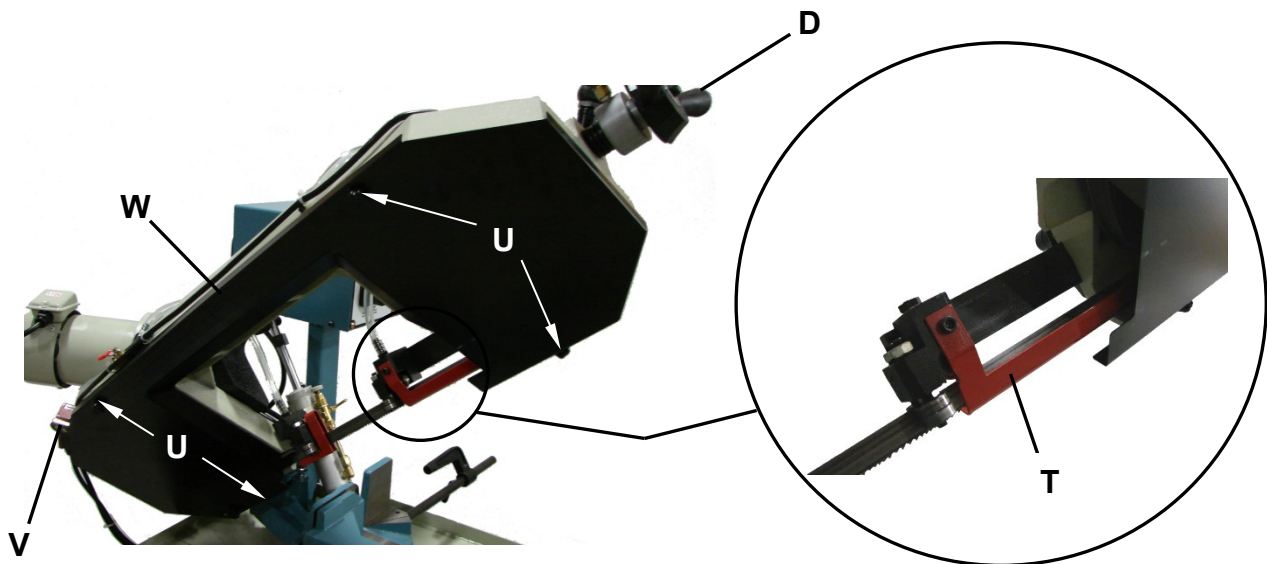
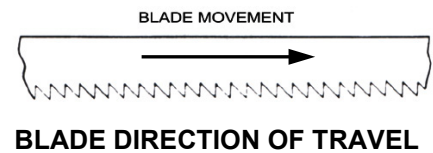



Setting Blade Tension

Blade tension is important to the proper operation of the saw. Correct blade tension is 90 kg/cm² as measured on the saws tension gauge.

Turning the handwheel (D) clockwise (cw) will increase the tension. Counterclockwise (ccw) will decrease tension of the saw blade.



Adjusting the Blade Tracking

The flywheel has been aligned at the factory and should not need any adjustment.

Over time, the flywheels alignment may need some adjustment to allow the saw blade to track correctly. Improper flywheel alignment can cause damage to the saw blade or cause it to ride off the blade wheel bearings.

1. Disconnect power from the saw.
2. Raise the saw bow to a usable work height and fully close the ball valve.
3. Loosen the hex socket cap screws (X, Y, & Z).
4. Use an allen wrench on setscrew (AA) to adjust the blade so that the blade teeth are approximately 0.19" (5mm) below the edge of the flywheel as shown.
5. Turning the setscrew (AA) clockwise (cw) will tilt flywheel so that the blade will ride closer to the flange.
6. Turning the setscrew (AA) counterclockwise (ccw) will tilt the flywheel so that the blade will ride away from the flange. (If it rides too far away it will come off).
7. After the adjustment is finished, tighten the socket cap screws in this order: (X, Y, & Z).

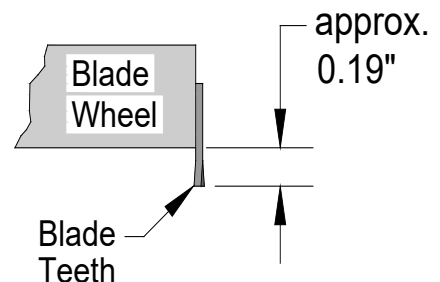
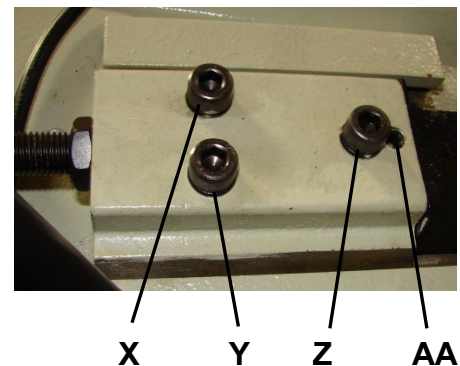

Checking the Adjustment of the Blade

Use a strip of scrap paper and slide it between the blade and the flywheel while it is running.

- If the paper is cut then the blade is riding too close to the flange. Readjust.
- If the paper folds or creases then the blade is seated properly.
- If the blade is riding away from the flange, then readjust.

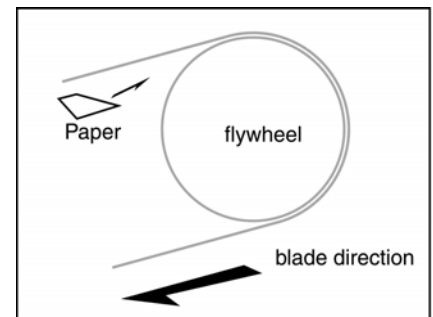



Adjusting the Blade Guide

1. Disconnect Power From the Saw.
2. Release the extension bar for the blade guide block by turning clamp handle (AC) counterclockwise (ccw) to loosen the clamping block (AD).
3. Hold the revolving handle (AB) and slide the blade guide block as close as possible to the piece part without interfering with the cut.
4. Tighten clamp handle (AC) clockwise (cw).

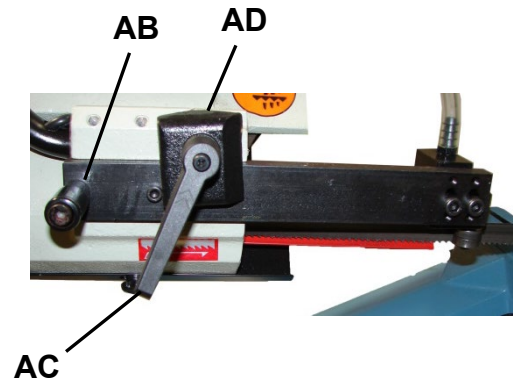

Blade Guide Bearing Adjustment

ATTENTION: This is the most important adjustment on your saw. It is impossible to get satisfactory work from your saw if the blade guides are not properly adjusted. This saw has been adjusted and power tested before leaving the factory to insure proper setting. If the guides do get out of adjustment, it is extremely important to re-adjust immediately. An improperly adjusted blade will not cut straight and serious blade damage may result. It is always best to try a new blade to see if this will correct poor cutting before beginning to adjust the blade guide bearings. If the blade becomes dull on one side and not the other, for example, it will begin cutting crooked. A blade change will correct this problem; the guide adjustment will not. If a new blade does not correct the problem, check the clearance between the blade and guides. Clearance should be from just touching to .001”.

1. Disconnect Power From the Saw.
2. Remove guard (AE) for access to the bearing.
3. Loosen nut (AF) on the eccentric bearing.
4. Turn adjusting nut (AG) clockwise (cw) to move the bearing away from the blade.
5. Turn the adjusting nut counterclockwise (ccw) to move the bearing closer to the blade.
6. After adjustment, retighten nut (AF) and replace guard (AE).

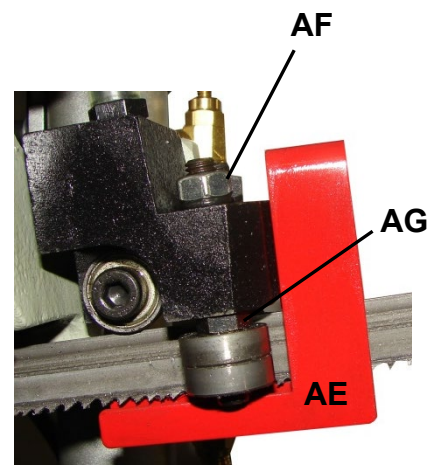



LUBRICATION AND MAINTENANCE



WARNING: Make sure the electrical disconnect is **OFF** before working on the machine.

Maintenance should be performed on a regular basis by qualified personnel.

Always follow proper safety precautions when working on or around any machinery.

- Check daily for any unsafe conditions and fix immediately.
- Check that all nuts and bolts are properly tightened.
- On a weekly basis clean the machine and the area around it.
- Lubricate threaded components and sliding devices.
- Apply rust inhibitive lubricant to all non-painted surfaces.

Daily Maintenance

- Do a general cleaning by removing dust and metal chips from the machine.
- Inspect the saw blade for wear.
- Top off the coolant tank.
- Clean the lubricating coolant drain screen.
- Check that the blade guards and emergency stop button are in good working order.
- When through using machine, raise the saw head to its up position and release some tension on the saw blade.

Weekly Maintenance

- Thoroughly clean the machine.
- Wipe and re-grease the vise screw and sliding surfaces.
- Remove chips from inside the guard housing for the saw blade.
- Use compressed air to clean the blade guides and guide bearings.

Monthly Maintenance

- Check the tightening of the motor flywheel screws.
- Check the blade guide bearings for wear. (replace if necessary)
- Tighten any loose bolts or screws on the gear motor, pump, and safety switches.
- Clean coolant tank



Six month maintenance

- Do a continuity check of the safety circuit



Note: Proper maintenance can increase the life expectancy of your machine.

Oils for Lubricating Coolant

Any 10:1 (water to coolant) solution will work, however we recommend Baileigh B-Cool 20:1 (water to coolant) biodegradable metal cutting fluid. It has excellent cooling and heat transfer characteristics, is non-flammable, and extends blade and machine life. Each gallon of concentrate makes 21 gallons of coolant.

Oil Disposal

Used oil products must be disposed of in a proper manner following your local regulations.

Coolant System Maintenance

1. Disconnect Power From the Saw
2. To clean the tank, first remove the pipe plug (AK) to drain the coolant.
3. Take off the screen (AL) by removing (4) screws.
4. Remove the pump (AM) by taking out (2) socket cap screws.
5. After tank is completely drained use a vacuum cleaner to remove all chips and debris.
6. Replace the plug.
7. Thoroughly clean the pump (AM) and replace.
8. Fill the tank with coolant to approximately 1" below the screen.
9. Replace the screen (AL). Removable drip tray (AN) shown in place

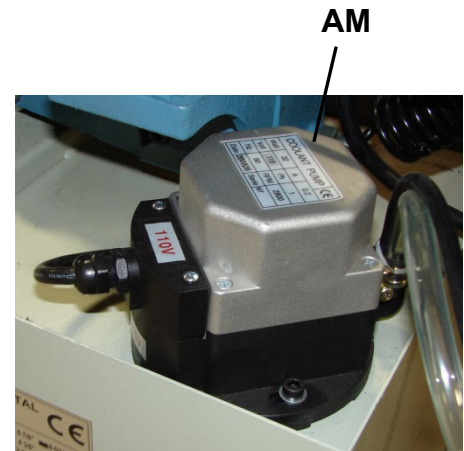
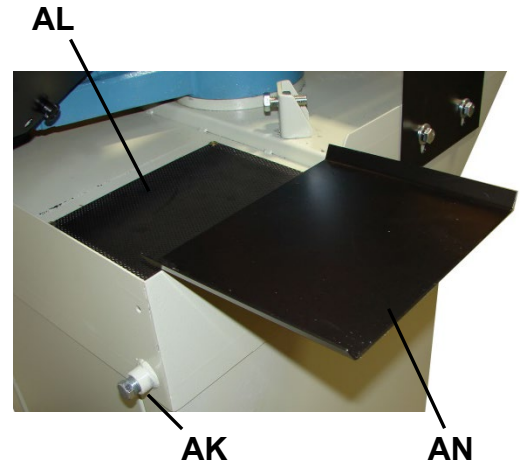



Gearbox Maintenance

The gearbox requires periodic changing of the oil. The first change should be between 2 and 6 months depending upon the amount of use. Thereafter the gearbox oil should be changed yearly.

1. Disconnect power from the saw
2. Raise the saw bow to a vertical position.



Note: You may have to back off the upper travel adjusting bolt.

3. Remove the oil drain plug (AO) and drain the oil into a catch basin. Loosening oil fill plug (AP) will help oil to drain.
4. After draining, replace drain plug (AO).
5. Return the saw bow to a horizontal position.
6. Remove the fill plug (AP) and add .32 quart of gear oil. (For reference use SHELL type gear oil or Mobil gear oil #90).

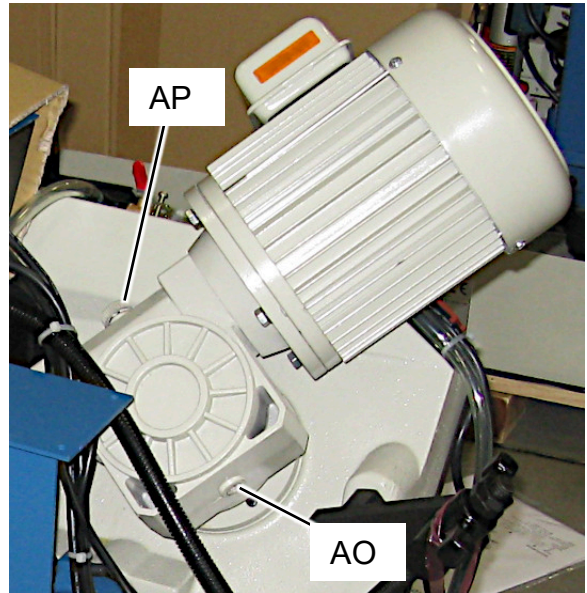

Storing Machine for Extended Period of Time

If the Band Saw is to be inactive for a long period of time, prepare the machine as follows:

1. Detach the plug from the electrical supply panel.
2. Clean and grease the machine.
3. Release tension on the blade or remove blade.
4. Cover the machine.
5. Drain coolant.



PARTS DIAGRAM AND PARTSLIST

Parts Diagram A

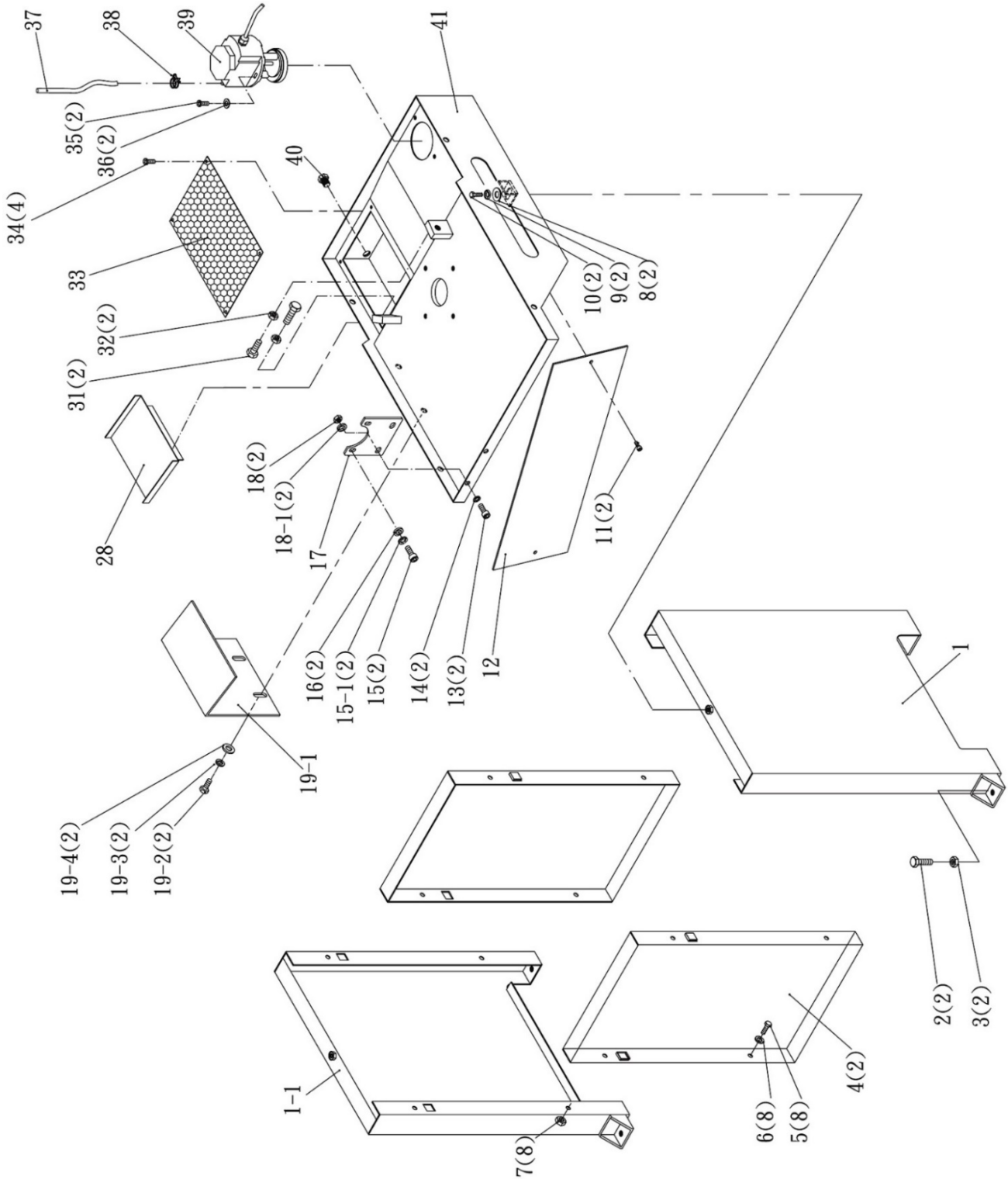



Parts Diagram B

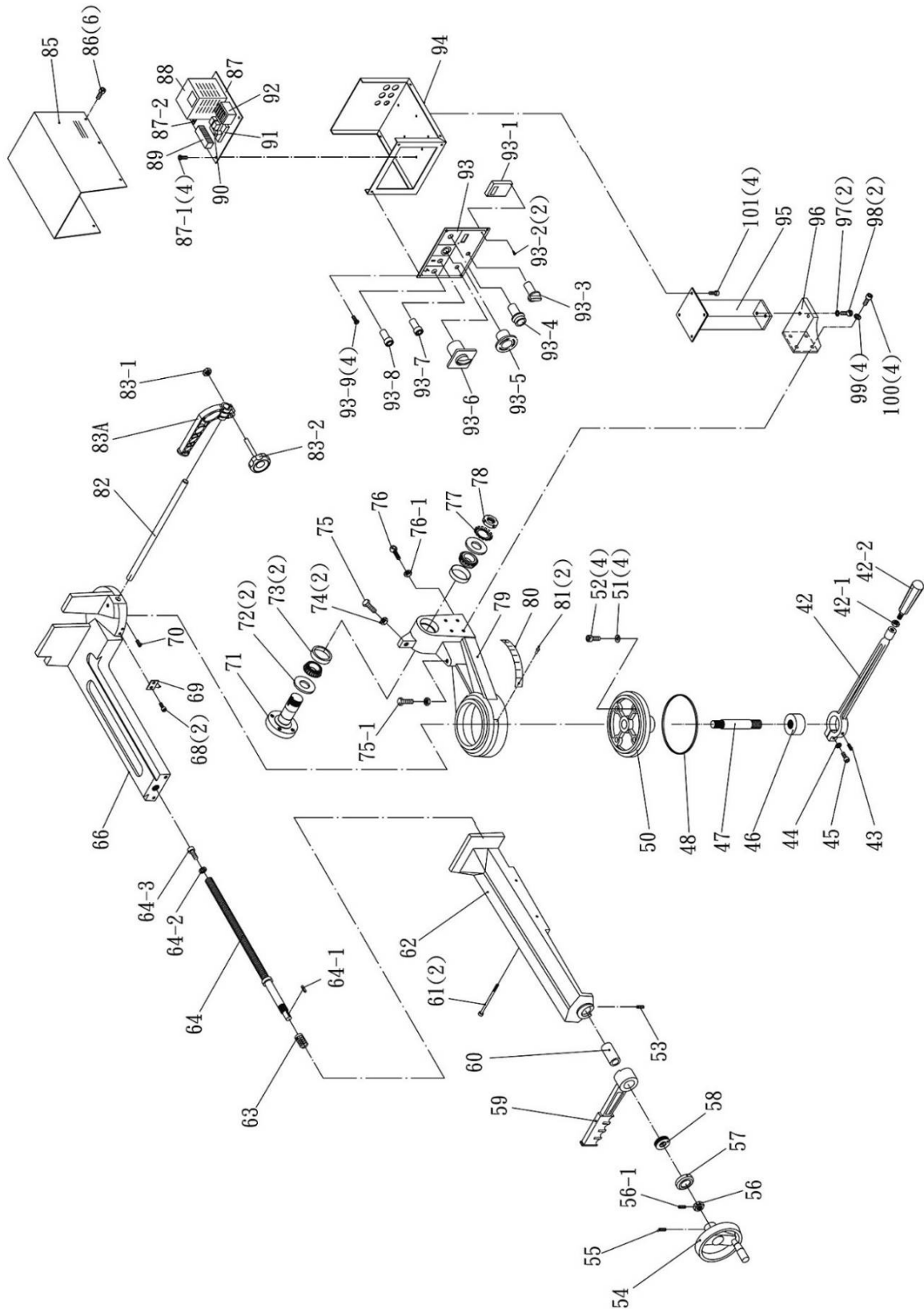



Parts Diagram C

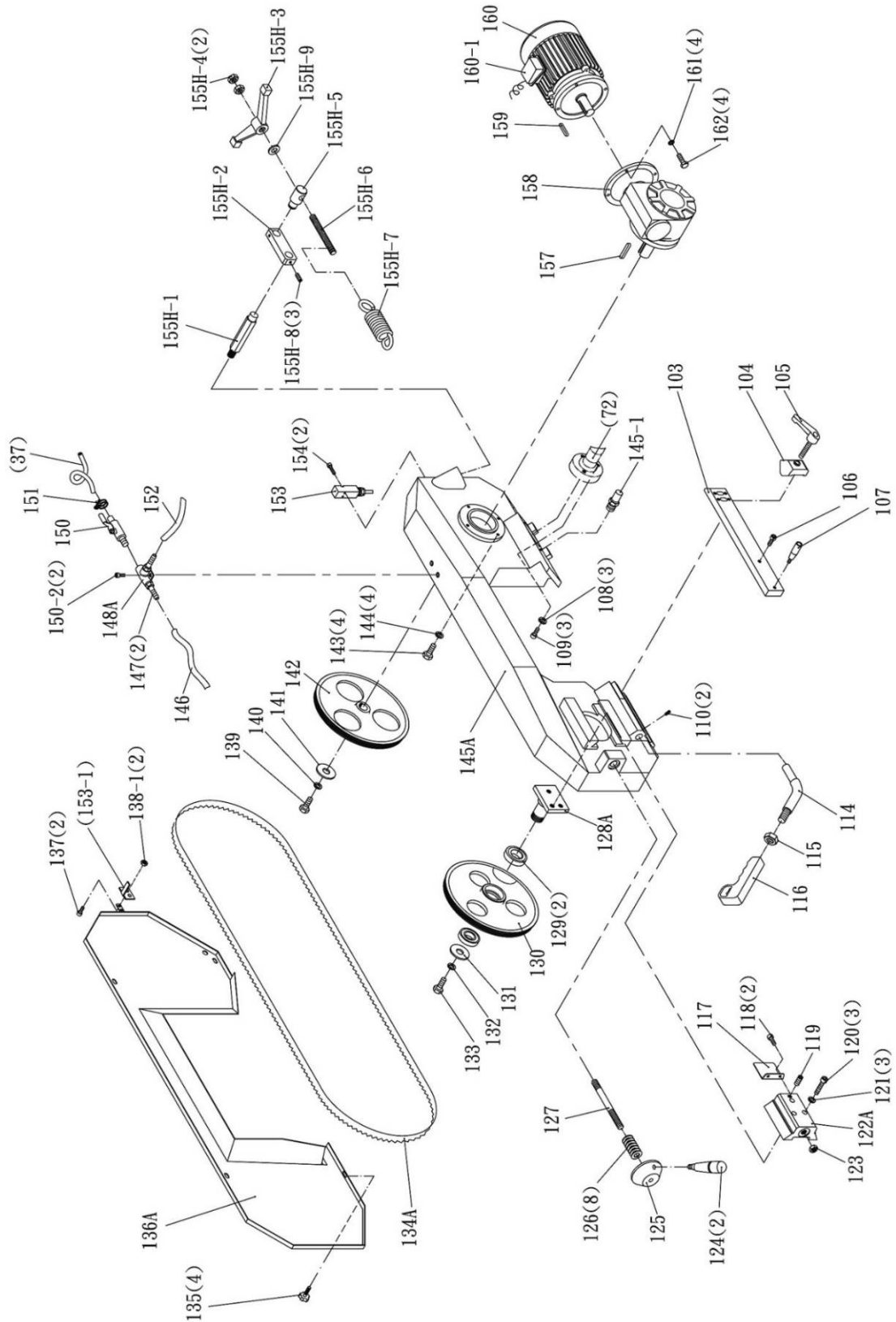

Parts Diagram D

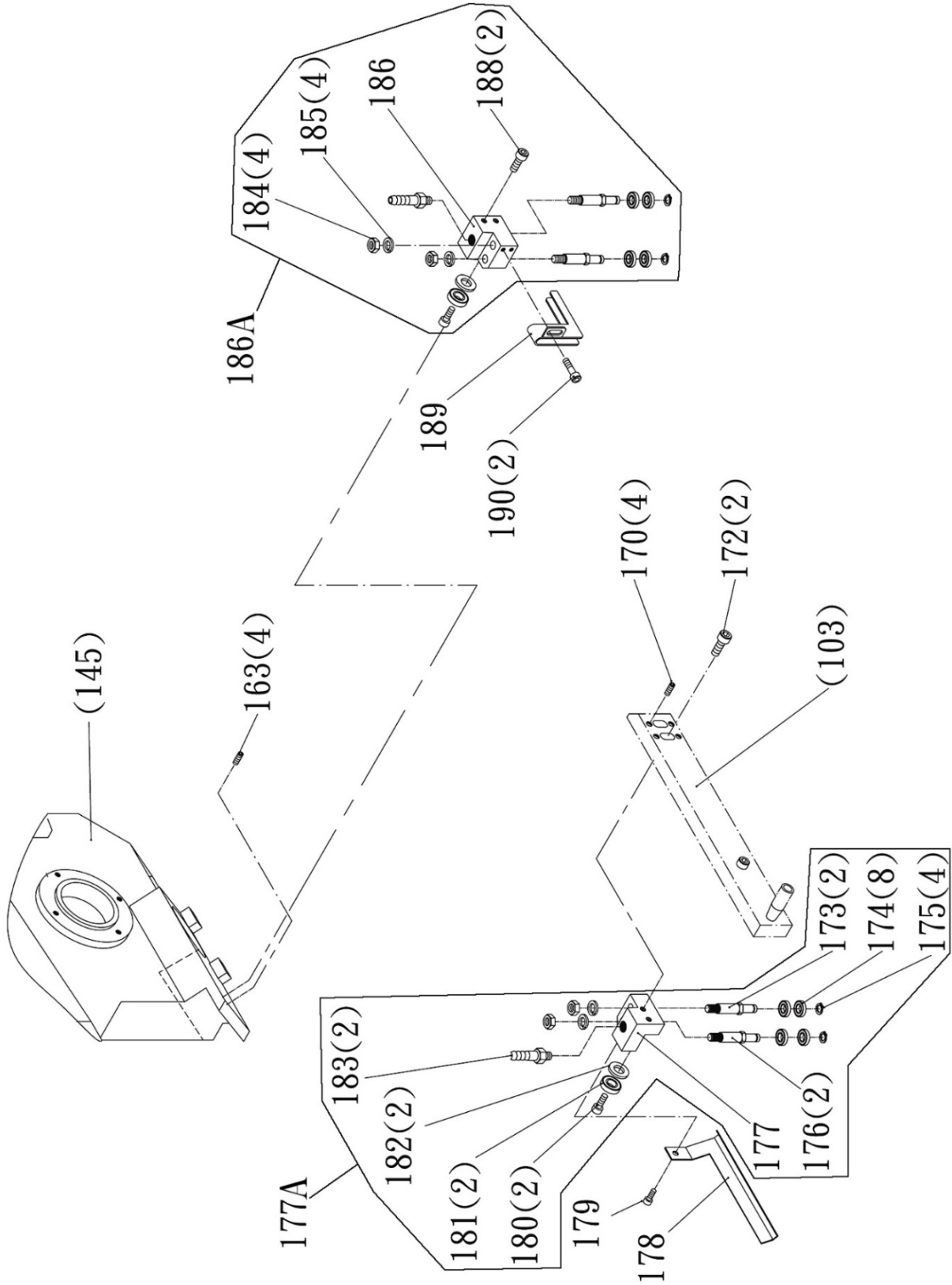



Parts List A – D

Index No	Part No.	Description	Size	Qty.
1	BS210M-1	Base (Right Part)		1
1-1	BS210M-1-1	Base (Left Part)		1
2	TS-1492041	Hex. Cap Bolt	M12x40	2
3	BS210M-3	Nut	M12	2
4	BS210M-4	Base Cover Plate		2
5	TS-1490021	Hex. Cap Bolt	M8x16	8
6	BS210M-6	Flat Washer	M8x18x2	8
7	BS210M-7	Nut	M8	8
8	BS210M-8	Flat Washer	M10x21x2	2
9	BS210M-9	Spring Washer	M10	2
10	TS-1505021	Hex. Socket Cap Screw	M10x20	2
11	TS-1503011	Hex. Socket Cap Screw	M6x8	2
12	BS210M-12	Plate		1
13	TS-1504041	Hex. Socket Cap Screw	M8x20	2
14	BS210M-14	Spring Washer	M8	2
15	TS-1504041	Hex. Socket Cap Screw	M8x20	2
15-1	BS210M-15-1	Spring Washer	M8	2
16	BS210M-16	Flat Washer	M8x18x2	2
17	BS210M-17	Supporting Plate		1
18	BS210M-18	Nut	M8	2
18-1	BS210M-18-1	Flat Washer	M8x18x2	2
19-1	BS210M-19-1	Support Plate		1
19-2	TS-1491021	Hex. Cap Bolt	M10x20	2
19-3	BS210M-19-3	Spring Washer	M10	2
19-4	BS210M-19-4	Flat Washer	M10x25x2	2
28	BS210M-28	Block Plate		1
31	TS-1492041	Hex. Cap Bolt	M12x40	2
32	BS210M-32	Nut	M12	2
33	BS210M-33	Filter Net		1
34	BS210M-34	Round Head Screw	M5x10	4
35	TS-1503061	Hex. Socket Cap Screw	M6x25	2
36	BS210M-36	Flat Washer	M6	2
37	BS210M-37	Hose	5/16"x125cm	1



Index No	Part No.	Description	Size	Qty.
38	BS210M-38	Hose Clamp		1
39	BS210M-39	Pump		1
40	BS210M-40	Plug	M3/8"	1
41	BS210M-41	Coolant and Chip Tray		1
42	BS210M-42	Locking Lever		1
42-1	BS210M-42-1	Nut	M12	1
42-2	BS210M-42-2	Handle		1
43	TS-1525031	Set Screw	M10x16	1
44	BS210M-44	Spring Washer	M10	1
45	TS-1505051	Hex. Socket Cap Screw	M10x35	1
46	BS210M-46	Nut		1
47	BS210M-47	Shaft		1
48	BS210M-48	Oil Seal	4mm (51.7-52cm)	1
50	BS210M-50	Disk		1
51	BS210M-51	Spring Washer	M8	4
52	TS-1504061	Hex. Socket Cap Screw	M8x30	4
53	TS-1524021	Set Screw	M8x10	1
54	BS210M-54	Hand Wheel	5-1/2"	1
55	TS-1524021	Set Screw	M8x10	1
56	BS210M-56	Nut	M20	1
56-1	BS210M-56-1	Set Screw	M5x5	1
57	BS210M-57	Bearing Bushing		1
58	BB-51104	Ball Bearing	#51104	1
59	BS210M-59	Lock Handle		1
60	BS210M-60	Bushing		1
61	TS-2236911	Hex. Socket Cap Screw	M6x100x28	2
62	BS210M-62	Movable Vise		1
63	BS210M-63	Compressed Spring		1
64	BS210M-64	Lead Screw		1
64-1	BS210M-64-1	Key	5x5x15	1
64-2	BS210M-64-2	Flat Washer	M8	1
64-3	TS-1504031	Hex. Socket Cap Screw	M8x16	1
66	BS210M-66	Vise Table		1
68	TS-1502011	Hex. Socket Cap Screw	M5x8	2
69	BS210M-69	Scale Point		1



Index No	Part No.	Description	Size	Qty.
70	TS-1524021	Set Screw	M8x10	1
71	BS210M-71	Pivot		1
72	BS210M-72	Anti-Bust Cover	Ø30	2
73	BB-32006	Ball Bearing	#32006	2
74	BS210M-74	Nut	M10	2
75	TS-1491061	Hex. Cap Bolt	M10x40	1
75-1	TS-1491031	Hex. Cap Bolt	M10x25	1
76	BS210M-76	Spring Hook		1
76-1	BS210M-76-1	Nut	M12	1
77	BS210M-77	Star Washer	Ø30	1
78	BS210M-78	Nut	M30	1
79	BS210M-79	Swing Arm		1
80	BS210M-80	Scale		1
81	BS210M-81	Rivet	2.3x4	2
82	BS210M-82	Bar-Stop-Rod		1
83A	BS210M-83A	Bar-Stop	Ø16	1
83-1	BS210M-83-1	Nut	M8	1
83-2	BS210M-83-2	Knob	M8x30	1
85	BS210M-85	Control Box Cover		1
86	TS-1502011	Hex. Socket Cap Screw	M5x8	6
87	BS210M-87	Control Box Bottom Plate		1
87-1	BS210M-87-1	Hex. Socket Cap Screw	M5	4
87-2	BS210M-87-2	Grounding Plate		1
88	BS210M-88	Inverter		1
89	BS210M-89	Terminal Connector		1
90	BS210M-90	Relay		1
91	BS210M-91	Fuse		1
92	BS210M-92	Transformer		1
93	BS210M-93	Control Box Panel		1
93-1	BS210M-93-1	Blade Speed Indicator		1
93-2	BS210M-93-2	Hex. Socket Cap Screw	M4	2
93-3	BS210M-93-3	Manual / Auto Selector		1
93-4	BS210M-93-4	Blade Speed Knob		1
93-5	BS210M-93-5	Emergency Switch		1
93-6	BS210M-93-6	Main Connect Switch		1



Index No	Part No.	Description	Size	Qty.
93-7	BS210M-93-7	Start Push Button		1
93-8	BS210M-93-8	Power Indicator Light		1
93-9	BS210M-93-9	Round Head Screw	M5x8	4
94	BS210M-94	Control Box Bottom Part		1
95	BS210M-95	Support		1
96	BS210M-96	Setting Bracket		1
97	BS210M-97	Spring Washer	M8	2
98	TS-1504041	Hex. Socket Cap Screw	M8x20	2
99	BS210M-99	Spring Washer	M8	4
100	TS-1504041	Hex. Socket Cap Screw	M8x20	4
101	TS-1502011	Hex. Socket Cap Screw	M5x8	4
103	BS210M-103	Front Ball Bearing Bracket		1
104	BS210M-104	Setting Bracket		1
105	BS210M-105	Handle	M10x45	1
106	TS-1503011	Hex. Socket Cap Screw	M6x8	1
107	BS210M-107	Plastic Handle	M6	1
108	BS210M-108	Spring Washer	M8	3
109	TS-1504051	Hex. Socket Cap Screw	M8x25	3
110	TS-1524021	Set Screw	M8x10	2
114	BS210M-114	Rod		1
115	BS210M-115	Nut	M16x2	1
116	BS210M-116	Trigger Switch		1
117	BS210M-117	Cover Plate		1
118	TS-1503011	Hex. Socket Cap Screw	M6x8	2
119	TS-1525051	Set Screw	M10x25	1
120	TS-1505061	Hex. Socket Cap Screw	M10x40	3
121	BS210M-121	Spring Washer	M10	3
122A	BS210M-122A	Slide		1
123	BS210M-123	Nut	M16x2	1
124	BS210M-124	Handle		2
125	BS210M-125	Handle Wheel		1
126	BS210M-126	Thrust Spring Washer		8
127	BS210M-127	Tension Shaft		1
128A	BS210M-128A	Shaft		1
129	BB-6006ZZ	Ball Bearing	#6006ZZ	2



Index No	Part No.	Description	Size	Qty.
130	BS210M-130	Idle Flywheel		1
131	BS210M-131	Washer		1
132	BS210M-132	Spring Washer	M10	1
133	TS-1491031	Hex. Cap Bolt	M10x25	1
134A	BS210M-134A	Blade		1
135	BS210M-135	Knob Bolt	M6x10	4
136A	BS210M-136A	Blade Cover		1
137	BS210M-137	Round Head Screw	M4x8	2
138-1	BS210M-138-1	Nut	M4	2
139	TS-1491031	Hex. Cap Bolt	M10x25	1
140	BS210M-140	Spring Washer	M10	1
141	BS210M-141	Washer		1
142	BS210M-142	Drive Flywheel		1
143	TS-1504071	Hex. Socket Cap Screw	M8x35	4
144	BS210M-144	Spring Washer	M8	4
145A	BS210M-145A	Saw Arm		1
145-1	BS210M-145-1	Set Shaft		1
146	BS210M-146	Hose	5/16"x75cm	1
147	BS210M-147	Pipe Fitting	1/4Px5/16	2
148A	BS210M-148A	T Connector		1
150	BS210M-150	Coolant Switch	1/4Px5/16	1
150-2	TS-1502021	Hex. Socket Cap Screw	M5x10	2
151	BS210M-151	Hose Clamp		1
152	BS210M-152	Hose	5/16"x35cm	1
153	BS210M-153	Limit Switch		1
153-1	BS210M-153-1	Switch Pin		1
154	TS-1501091	Hex. Socket Cap Screw	M4x35	2
155H-1	BS210M-155H-1	Spring Shaft		1
155H-2	BS210M-155H-2	Setting Plate		1
155H-3	BS210M-155H-3	Handle		1
155H-4	BS210M-155H-4	Nut	M16x2.0x8t	2
155H-5	BS210M-155H-5	Bushing		1
155H-6	BS210M-155H-6	Adjustable Shaft		1
155H-7	BS210M-155H-7	Spring		1
155H-8	TS-1524021	Set Screw	M8x10	3



Index No	Part No.	Description	Size	Qty.
155H-9	BS210M-155H-9	Flat Washer	M16	1
157	BS210M-157	Key	7x7x25	1
158	BS210M-158	Gear Box		1
159	BS210M-159	Key	5x5x25	1
160	BS210M-160	Motor		1
160-1	BS210M-160-1	Junction Box		1
161	BS210M-161	Spring Washer	M8	4
162	TS-1490041	Hex. Cap Bolt	M8x25	4
163	TS-1523041	Set Screw	M6x12	4
170	TS-1523041	Set Screw	M6x12	4
172	TS-1504051	Hex. Socket Cap Screw	M8x25	2
173	BS210M-173	Centric Shaft		2
174	BB-608ZZ	Ball Bearing	#608ZZ	8
175	BS210M-175	E Ring	E7	4
176	BS210M-176	Eccentric Shaft		2
177	BS210M-177	Front Ball Bearing Seat		1
177A	BS210M-177A	Front Guide Assembly		
178	BS210M-178	Front Blade Guard		1
179	TS-1503011	Hex. Socket Cap Screw	M6x8	1
180	TS-1504041	Hex. Socket Cap Screw	M8x20	2
181	BB-608ZZ	Ball Bearing	#608ZZ	2
182	BS210M-182	Spring Washer	M8	2
183	BS210M-183	Pipe Fitting	1/4Px5/16	2
184	BS210M-184	Nut	M8	4
185	BS210M-185	Spring Washer	M8	4
186	BS210M-186	Rear Ball Bearing Seat		1
186A	BS210M-186A	Rear Guide Assembly		
188	TS-1504051	Hex. Socket Cap Screw	M8x25	2
189	BS210M-189	Rear Blade Guard		1
190	BS210M-190	Round Head Screw	M6x8	2

LIFT ASSEMBLY PARTS DIAGRAM E

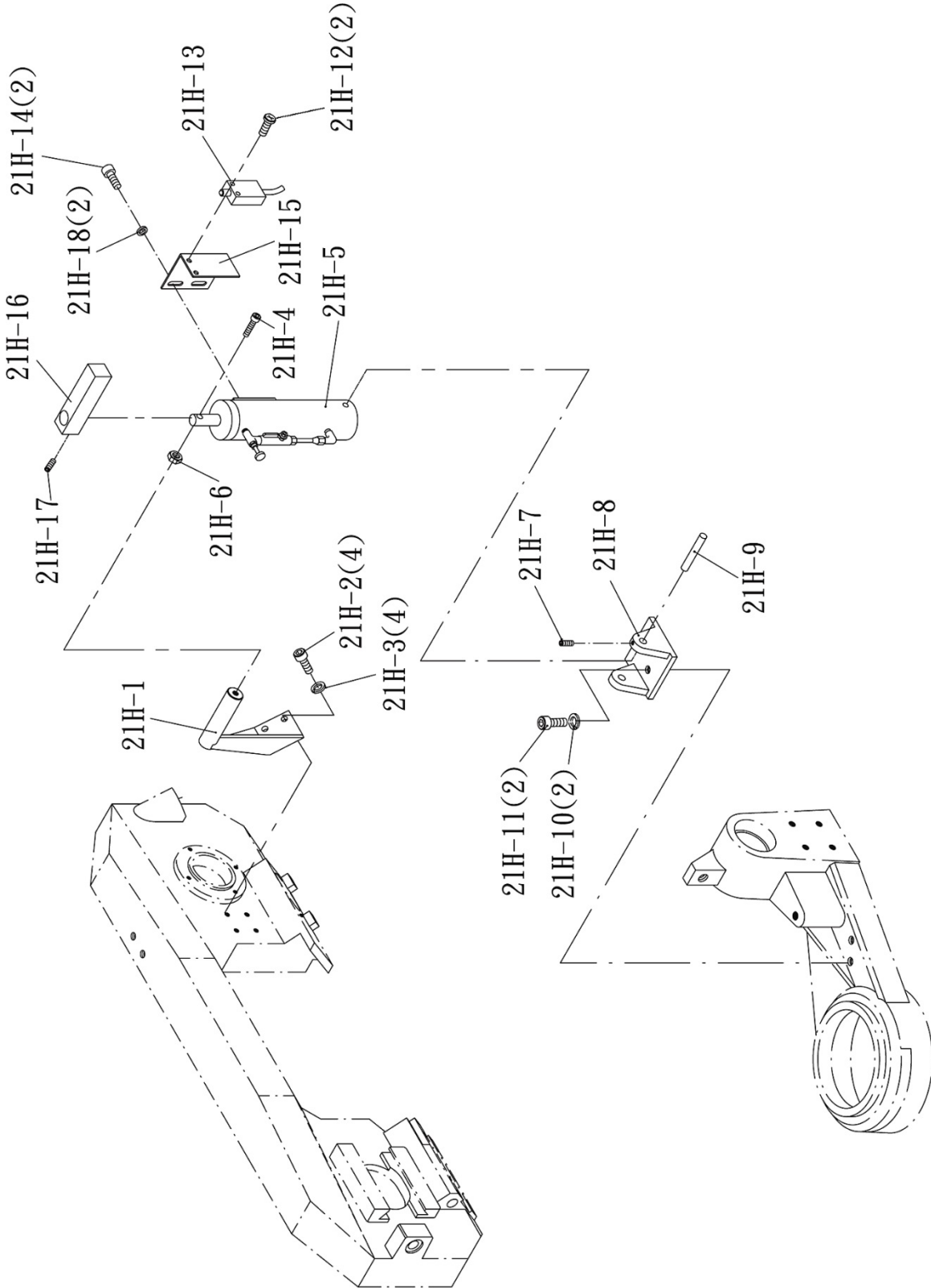



Lift Assembly Parts List E

Index No	Part No.	Description	Size	Qty.
21H-1	BS210M-21H-1	Top Support		1
21H-2	TS-1504041	Hex Socket Cap Screw	M8 x 20	4
21H-3	BS210M-21H-3	Spring Washer M8		4
21H-4	TS-1505061	Hex Socket Cap Screw	M10 x 40	1
21H-5	BS210M-21H-5	Hydraulic Cylinder		1
21H-6	BS210M-21H-6	Nut	M10	1
21H-7	TS-1523041	Set Screw	M6 x 12	1
21H-8	BS210M-21H-8	Bottom Support		1
21H-9	BS210M-21H-9	Support Rod		1
21H-10	BS210M-21H-10	Spring Washer	M8	2
21H-11	TS-1504041	Hex Socket Cap Screw	M8 x 20	2
21H-12	BS210M-21H-12	Round Head Screw	M5 x 10	2
21H-13	BS210M-21H-13	Limit Switch		1
21H-14	TS-1503011	Hex Socket Cap Screw	M6 x 8	2
21H-15	BS210M-21H-15	Adjusting Bracket		1
21H-16	BS210M-21H-16	Setting Bracket		1
21H-17	TS-1523041	Set Screw	M6 x 12	1
21H-18	BS210M-21H-18	Washer	M6	2



ELECTRICAL SCHEMATIC

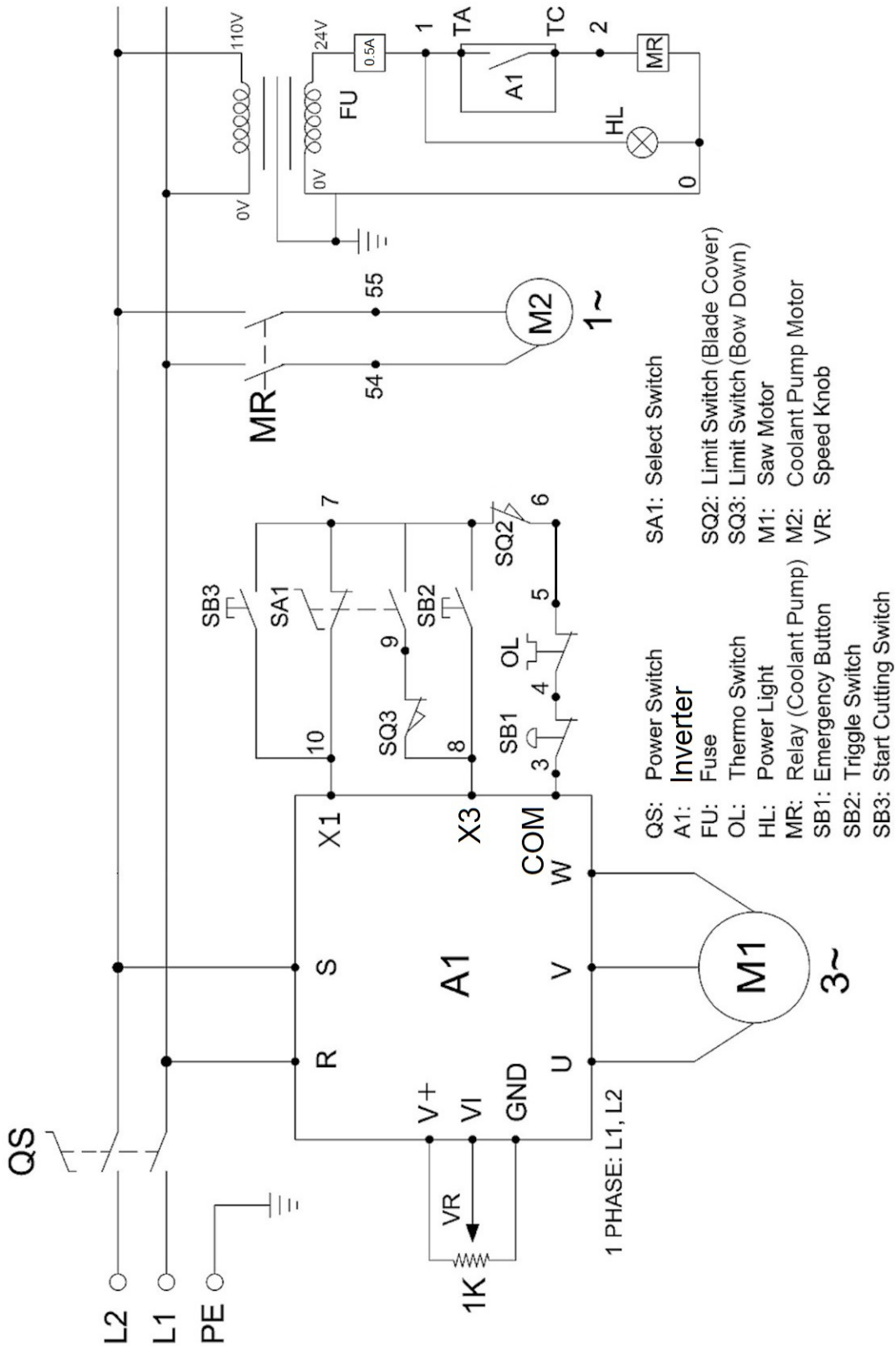



FAULT DISPLAYS

Error Trip Messages of Drive

Display	Description	Display	Description
Fot 	IGBT module error	noFb 	PID feedback signal error
GF 	Grounding fault	AdEr 	A/D converter error
OC 	Drive over current	EF 	External fault
OL 	Motor overload	PAdF 	Keypad interruption during copy
OL1 	Drive overload	EEr 	EEPROM error
OL2 	Drive current limit	EEr1 	Internal memory error
OL3 	Braking transistor overload	EEr2 	Internal memory error
OLO 	System overload	ntcF 	Thermal sensor fault
OE 	Over voltage	OH 	Drive overheat
LE1 	Under voltage during operation	OH2 	Motor overheat



Warning Messages of Drive

Display	Description	Display	Description
OLO 	System overload	Fr 	Coast to stop
Hv 	Power source over voltage	dtF 	Forward/reverse command input simultaneously
db 	Braking transistor is active	WrF 	Different software version inter-copy
LE* 	Power source under voltage*	Cot 	Modbus communication overtime
Oht 	Drive overheat	Err 00 	Keypad cable trip before connecting
OH1 	Motor overheat	Err 01 	Keypad cable trip during operation
Bb 	Drive output interruption	PUF1 	First time you enter wrong
PUF2 	Second time you enter wrong	PUF3 	Third time you enter wrong
LOC 	Parameter locking	ULOC 	Parameter Password Unlock



Note: *The LE error message will display briefly when power is removed from the machine. This is normal as it is accurately reading a loss of power.



TROUBLESHOOTING



WARNING: Make sure the electrical disconnect is OFF before working on the machine.

SYMPTOM	POSSIBLE CAUSE (S)	CORRECTIVE ACTION
Saw Motor Does Not Stop When Cut is Finished	<ol style="list-style-type: none"> 1. Actuator on cylinder does not contact switch properly. 2. Bow down limit switch SQ3 damaged 	<ol style="list-style-type: none"> 1. Re-adjust actuator or switch. 2. Replace SQ3
Coolant Motor Does Not Run With Band Saw Motor	<ol style="list-style-type: none"> 1. Coolant switch not turned ON. 2. Coolant motor M2 damaged. 	<ol style="list-style-type: none"> 1. Turn on coolant switch. 2. Replace M2 motor.
No Power Indicator Light When Main Power Turned On	<ol style="list-style-type: none"> 1. Fuse may have burned out. 2. Transformer T1 damaged 3. Power LED HL1 damaged 	<ol style="list-style-type: none"> 1. Switch off main power. Replace defective fuse 2. Replace Transformer 3. Replace (white) power LED
Excessive Blade Breakage	<ol style="list-style-type: none"> 1. Material loose in vise 2. Incorrect speed or feed 3. Blade tooth spacing too large 4. Material too coarse 5. Incorrect blade tension 6. Teeth in contact with material before saw is started 7. Blade rubs on wheel flange 8. Misaligned guide bearings 9. Cracking at weld 	<ol style="list-style-type: none"> 1. Clamp work securely 2. Adjust speed or feed 3. Replace with a small tooth spacing blade 4. Use a slow speed blade an small tooth spacing 5. Adjust to where blade does not slip on wheel 6. Start saw and lower into work piece 7. Adjust wheel alignment 8. Adjust guide bearings 9. Weld again, note quality of weld
Premature Blade Dulling	<ol style="list-style-type: none"> 1. Teeth too coarse 2. Too much speed 3. Inadequate feed pressure 4. Hard spots or scale on material 5. Work hardening of material 6. Blade twist 7. Insufficient blade 	<ol style="list-style-type: none"> 1. Use finer teeth 2. Decrease speed 3. Decrease spring tension on side of saw 4. Reduce speed, increase feed pressure 5. Increase feed pressure by reducing spring tension 6. Replace with a new blade, and adjust blade tension 7. Tighten blade tension adjustable knob



SYMPTOM	POSSIBLE CAUSE (S)	CORRECTIVE ACTION
Unusual Wear on Side/Back of Blade	<ol style="list-style-type: none"> 1. Blade guides worn 2. Blade guide bearings not adjusted properly 3. Blade guide bearing bracket is loose 	<ol style="list-style-type: none"> 1. Replace 2. Adjust as per operators manual 3. Tighten
Teeth Ripping From Blade	<ol style="list-style-type: none"> 1. Teeth too coarse for work 2. Too heavy pressure, too slow speed 3. Vibrating work piece 4. Gullets loading 	<ol style="list-style-type: none"> 1. Use finer tooth blade 2. Decrease pressure, increase speed 3. Clamp work piece securely 4. Use coarse tooth blade or brush to remove chips
Poor Cuts	<ol style="list-style-type: none"> 1. Feed pressure too great 2. Guide bearing not adjusted properly 3. Inadequate blade tension 4. Dull blade 5. Speed incorrect 6. Blade guide spaced out too much 7. Blade guide assembly loose 8. Blade track too far away from wheel flanges 	<ol style="list-style-type: none"> 1. Reduce pressure by increasing spring tension on side of saw 2. Adjust guide bearing, the clearance can not be greater than .001mm 3. Increase blade tension with tension knob 4. Replace blade 5. Adjust speed 6. Adjust guide space 7. Tighten blade guide assembly 8. Re-track blade according to operating instructions
Poor Cuts (Rough)	<ol style="list-style-type: none"> 1. Too much speed or feed 2. Blade is too coarse 3. Blade tension loose 	<ol style="list-style-type: none"> 1. Decrease speed or feed 2. Replace with finer blade 3. Adjust blade tension
Blade is Twisting	<ol style="list-style-type: none"> 1. Cut is binding blade 2. Too much blade tension 	<ol style="list-style-type: none"> 1. Decrease feed pressure 2. Decrease blade tension

BAILEIGH INDUSTRIAL HOLDINGS LLC
1625 DUFEEK DRIVE MANITOWOC, WI 54220
PHONE: 920. 684. 4990 FAX: 920. 684. 3944
www.baileigh.com