



MAINTENANCE / PARTS MANUAL

Metal Working



HYDRAULIC SHEAR MODEL: SH-8003HD

Baileigh Industrial, Inc.
P.O. Box 531
Manitowoc, WI 54221-0531
Phone: 920.684.4990
Fax: 920.684.3944
sales@baileigh.com

Book 2 of 2

REPRODUCTION OF THIS MANUAL IN ANY FORM WITHOUT WRITTEN APPROVAL OF BAILEIGH INDUSTRIAL, INC. IS PROHIBITED. Baileigh Industrial, Inc. does not assume and hereby disclaims any liability for any damage or loss caused by an omission or error in this Operator's Manual, resulting from accident, negligence, or other occurrence.

Rev. 11/2018

© 2018 Baileigh Industrial, Inc.



Table of Contents

SAFETY INSTRUCTIONS	1
SAFETY PRECAUTIONS	3
Dear Valued Customer:.....	3
Electrical Enclosure Disconnect Switch.....	6
Hazard Signs.....	6
MATERIAL SELECTION.....	7
MACHINE ADJUSTMENTS	7
Blade Clearance	7
Suggested Knife Clearance.....	8
REPLACING THE SHEAR BLADES.....	9
To Rotate or Replace the Top Blade	10
To Rotate or Replace the Bottom Blade	11
KNIFE BAR WAYS ADJUSTMENT.....	12
LUBRICATION AND MAINTENANCE	13
Roller Lubrication.....	13
Hydraulic Oil	14
Oil Change and Disposal.....	14
Storing Machine for Extended Period of Time	14
HYDRAULIC SCHEMATIC	15
MANIFOLD BLOCK	16
Hydraulic Component Identification	17
ELECTRICAL ENCLOSURE BACK PANEL	18
ELECTRICAL COMPONENT IDENTIFICATION	19
Electrical Parts List.....	20
Additional Electrical Components.....	20
ELECTRICAL SCHEMATIC (Sheet. 1)	21
ELECTRICAL SCHEMATIC (Sheet 2)	22
ELECTRICAL SCHEMATIC (Sheet 3)	23
ELECTRICAL WIRE TERMINALS	24
MECHANICAL REPLACEMENT PARTS.....	25
MAIN FRAME PARTS DIAGRAM.....	26
Main Frame Parts List	29
HYDRAULIC CYLINDER-PARTS DIAGRAM.....	31
Hydraulic Cylinder Parts List.....	32
HOLD DOWN CYLINDER PARTS DIAGRAM	33
Hold Down Cylinder Parts List.....	33
BACK GAUGE PARTS DIAGRAM.....	34
Back Gauge Parts List.....	35
TROUBLESHOOTING	36



IMPORTANT

PLEASE READ THIS OPERATORS MANUAL CAREFULLY

It contains important safety information, instructions, and necessary operating procedures. The continual observance of these procedures will help increase your production and extend the life of the equipment.

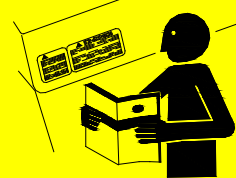

SAFETY INSTRUCTIONS

LEARN TO RECOGNIZE SAFETY INFORMATION

This is the safety alert symbol. When you see this symbol on your machine or in this manual, **BE ALERT TO THE POTENTIAL FOR PERSONAL INJURY!**



Follow recommended precautions and safe operating practices.

UNDERSTAND SIGNAL WORDS

A signal word – **DANGER**, **WARNING**, or **CAUTION** – is used with the safety alert symbol. **NOTICE**, which is not related to personal injury, is used without a symbol.

DANGER: Indicates a hazardous situation which, if not avoided, will result in death or serious injury.

WARNING: Indicates a hazardous situation which, if not avoided, could result in death or serious injury.

CAUTION: Indicates a hazardous situation which, if not avoided, could result in minor or moderate injury.

NOTICE: Indicates a situation which, if not avoided, could result in property damage.



DANGER



WARNING



CAUTION



NOTICE



SAVE THESE INSTRUCTIONS.
Refer to them often and use them to instruct others.



PROTECT EYES

Wear safety glasses or suitable eye protection when working on or around machinery.

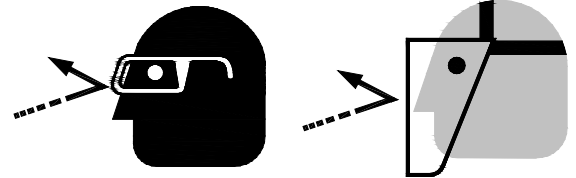

HYDRAULIC HOSE FAILURE

Exercise **CAUTION** around hydraulic hoses in case of a hose or fitting failure.

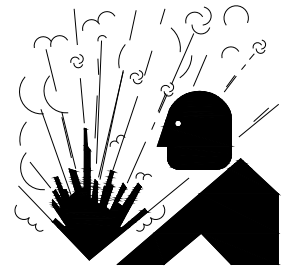

PROTECT AGAINST NOISE

Prolonged exposure to loud noise can cause impairment or loss of hearing. Wear suitable hearing protective devices such as ear muffs or earplugs to protect against objectionable or uncomfortable loud noises.

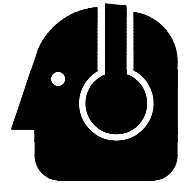

BEWARE OF SHEAR HAZARD

Blade is sharp. Placing hands or fingers near blade will result in cuts and possibly loss of fingers or limbs if placed in machine. **NEVER** place your hand or any part of your body in this machine.

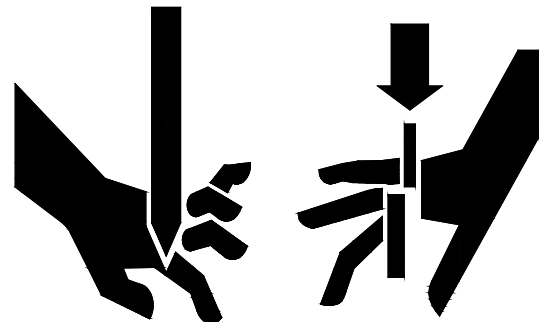



Emergency Stop Button

In the event of incorrect operation or dangerous conditions, the machine can be stopped immediately by pressing the **E-STOP** button. Twist the emergency stop button clockwise (cw) to reset. Note: Resetting the E-Stop will not start the machine.

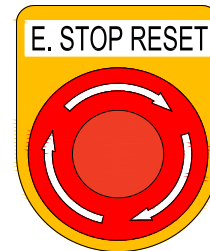

SAFETY PRECAUTIONS



Metal working can be dangerous if safe and proper operating procedures are not followed. As with all machinery, there are certain hazards involved with the operation of the product. Using the machine with respect and caution will considerably lessen the possibility of personal injury. However, if normal safety precautions are overlooked or ignored, personal injury to the operator may result.

Safety equipment such as guards, hold-downs, safety glasses, dust masks and hearing protection can reduce your potential for injury. But even the best guard won't make up for poor judgment, carelessness or inattention. **Always use common sense** and exercise **caution** in the workshop. If a procedure feels dangerous, don't try it.

REMEMBER: Your personal safety is your responsibility.



WARNING: FAILURE TO FOLLOW THESE RULES MAY RESULT IN SERIOUS PERSONAL INJURY

Dear Valued Customer:

- All Baileigh machines should be used only for their intended use.
- Baileigh does not recommend or endorse making any modifications or alterations to a Baileigh machine. Modifications or alterations to a machine may pose a substantial risk of injury to the operator or others and may do substantial damage to the machine.
- Any modifications or alterations to a Baileigh machine will invalidate the machine's warranty.

PLEASE ENJOY YOUR BAILEIGH MACHINE!PLEASE ENJOY IT SAFELY!



1. **FOR YOUR OWN SAFETY, READ INSTRUCTION MANUAL BEFORE OPERATING THE MACHINE.** Learn the machine's application and limitations as well as the specific hazards.
2. **Only trained and qualified personnel can operate this machine.**
3. **Make sure guards are in place and in proper working order before operating machinery.**
4. **Remove any adjusting tools.** Before operating the machine, make sure any adjusting tools have been removed.
5. **Keep work area clean.** Cluttered areas invite injuries.
6. **Overloading machine.** By overloading the machine, you may cause injury from flying parts. **DO NOT** exceed the specified machine capacities.
7. **Dressing material edges.** Always chamfer and deburr all sharp edges.
8. **Do not force tool.** Your machine will do a better and safer job if used as intended. **DO NOT** use inappropriate attachments in an attempt to exceed the machine's rated capacity.
9. **Use the right tool for the job. DO NOT** attempt to force a small tool or attachment to do the work of a large industrial tool. **DO NOT** use a tool for a purpose for which it was not intended.
10. **Dress appropriately. DO NOT** wear loose fitting clothing or jewelry as they can be caught in moving machine parts. Protective clothing and steel toe shoes are recommended when using machinery. Wear a restrictive hair covering to contain long hair.
11. **Use eye and ear protection.** Always wear ISO approved impact safety goggles. Wear a full-face shield if you are producing metal filings.
12. **Do not overreach.** Maintain proper footing and balance at all times. **DO NOT** reach over or across a running machine.
13. **Stay alert.** Watch what you are doing and use common sense. **DO NOT** operate any tool or machine when you are tired.
14. **Check for damaged parts.** Before using any tool or machine, carefully check any part that appears damaged. Check for alignment and binding of moving parts that may affect proper machine operation.
15. **Observe work area conditions. DO NOT** use machines or power tools in damp or wet locations. Do not expose to rain. Keep work area well lighted. **DO NOT** use electrically powered tools in the presence of flammable gases or liquids.
16. **Blade adjustments and maintenance.** Always keep blades sharp and properly adjusted for optimum performance.
17. **Keep children away.** Children must never be allowed in the work area. **DO NOT** let them handle machines, tools, or extension cords.
18. **Keep visitors a safe distance from the work area.**



19. **Store idle equipment.** When not in use, tools must be stored in a dry location to inhibit rust. Always lock up tools and keep them out of reach of children.
20. **DO NOT operate machine if under the influence of alcohol or drugs.** Read warning labels on prescriptions. If there is any doubt, **DO NOT** operate the machine.
21. **DO NOT** touch live electrical components or parts.
22. **Turn off** power before checking, cleaning, or replacing any parts.
23. Be sure **all** equipment is properly installed and grounded according to national, state, and local codes.
24. Inspect power and control cables periodically. Replace if damaged or bare wires are exposed. **Bare wiring can kill!**
25. **DO NOT** bypass or defeat any safety interlock systems.



Electrical Enclosure Disconnect Switch

⚠ WARNING: Before opening the door to work on electrical circuits, turn the main disconnect switch “OFF”. Also turn off and Lock Out the electrical supply source to this machine. **FAILURE TO FOLLOW THESE INSTRUCTIONS MAY RESULT IN FATAL OR SERIOUS INJURY.**

The main disconnect switch (P) turns power on to the machine when in the “ON” position. If the door handle is turned while the switch is “ON”, a safety catch will prevent the door from opening.

Hazard Signs

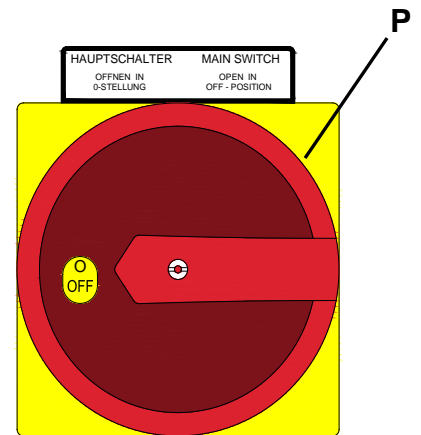
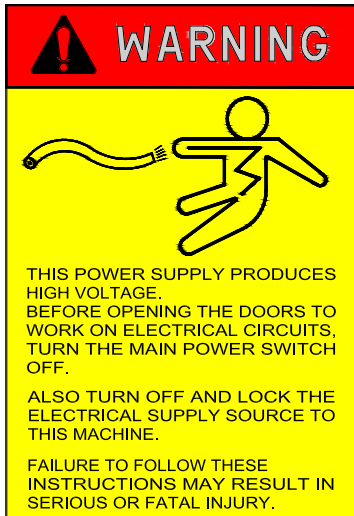



MATERIAL SELECTION

⚠ CAUTION: It must be determined by the customer that materials being processed through the machine are **NOT** potentially hazardous to operator or personnel working nearby.

When selecting materials keep these instructions in mind:

- Material must be clean and dry. (without oil)
- Material should have a smooth surface so it processes easily.
- Dimensional properties of material must be consistent and not exceed the machine capacity values.
- Chemical structure of material must be consistent.
- Buy certificated steel from the same vendor when possible.

MACHINE ADJUSTMENTS

Blade Clearance

1. Allowed the knife bar to slowly drop and the cutting edges to begin to cross / interfere. Check with a feeler gauge for 0.031" (0.8mm) clearance between blades on the right side.
2. Check the blade clearance from the right to the left as the knife-bar moves downward. The clearance should be 0.031" (0.8mm) on each side & 0.023" (0.6mm) in the center. The clearance must be checked at the exact center point of intersection of the blades to obtain accurate indications.
3. If clearance is not correct loosen the table bolt & move the table in or out. Use the square set screws to push the table in (= reduce clearance), and the hex socket cap screws to pull the table out (= increase clearance). Use the control screws alternately so as not to force one screw against the other & to maintain complete control over the table as all times. Check clearances after the table bolts have been tightened and the control screws snugged up to determine if any settings have changed.
4. To change the clearance as the center of the blade, adjust the nut.
5. This blade clearance checking and adjustment procedures must be followed whenever the blades are changed or reversed.
6. Check with feeler gauge between the wear plate and the knife bar along the lower gear surface and top rear surface that a proper clearance has been established.
7. Repeats step 2 through 6 on the L.H. end of the shear.
8. Check blade clearance and adjust it necessary.



Suggested Knife Clearance



Note: This is a general guide for setting the blade gap. Your specific settings may change based upon several factors regarding specific material and other machine settings and conditions. This is based upon a general guideline of blade gap is equal to 6.5%-7% of material thickness.

Gauge (ga)	Standard Steel Thickness	Aluminum Thickness	Knife Blade Clearance
3	0.2391 (6.073mm)	0.2294 (5.827mm)	.010"-0.018" (.25-.45mm)
4	0.2242 (5.695mm)	0.2043 (5.189mm)	.009"-0.013" (.23-.33mm)
5	0.2092 (5.314mm)	0.1819 (4.620mm)	.009"-0.013" (.23-.33mm)
6	0.1943 (4.935mm)	0.162 (4.115mm)	.009"-0.013" (.23-.33mm)
7	0.1793 (4.554mm)	0.1443 (3.665mm)	.008"-0.011" (.20-.28mm)
8	0.1644 (4.176mm)	0.1285 (3.264mm)	.007"-0.010" (.17-.25mm)
9	0.1495 (3.797mm)	0.1144 (2.906mm)	.006"-0.009" (.15-.23mm)
10	0.1345 (3.416mm)	0.1019 (2.588mm)	.006"-0.009" (.15-.23mm)
11	0.1196 (3.038mm)	0.0907 (2.304mm)	.004"-0.008" (.10-.20mm)
12	0.1046 (2.657mm)	0.0808 (2.052mm)	.004"-0.008" (.10-.20mm)
13	0.0897 (2.278mm)	0.072 (1.829mm)	.003"-0.006" (.076-.152mm)
14	0.0747 (1.897mm)	0.0641 (1.628mm)	.003"-0.006" (.076-.152mm)
15	0.0673 (1.709mm)	0.0571 (1.450mm)	.003"-0.006" (.076-.152mm)
16	0.0598 (1.519mm)	0.0508 (1.290mm)	.002"-0.005" (.05-.127mm)
17	0.0538 (1.367mm)	0.0453 (1.151mm)	.002"-0.005" (.05-.127mm)
18	0.0478 (1.214mm)	0.0403 (1.024mm)	.002"-0.004" (.05-.10mm)
19	0.0418 (1.062mm)	0.0359 (0.912mm)	.002"-0.004" (.05-.10mm)
20	0.0359 (0.912mm)	0.032 (0.813mm)	.002"-0.004" (.05-.10mm)
21	0.0329 (0.836mm)	0.0285 (0.724mm)	.002"-0.004" (.05-.10mm)
22	0.0299 (0.759mm)	0.0253 (0.643mm)	.002"-0.004" (.05-.10mm)
23	0.0269 (0.683mm)	0.0226 (0.574mm)	.001"-0.003" (.025-.076mm)
24	0.0239 (0.607mm)	0.0201 (0.511mm)	.001"-0.003" (.025-.076mm)



REPLACING THE SHEAR BLADES

⚠ WARNING: The shearing blade poses an amputation hazard. Make sure no body part or clothing is near the specific hazard. Failure to follow this warning could result in severed or crushed fingers.

The blades on the Baileigh shear have multiple usable edges. If you have not already used both cutting edges on the top blade you can rotate it end for end to expose a sharp edge. The bottom blade has four usable edges. After all edges have been used, the blade can be reground or replaced. Contact Baileigh Industrial at (920.684.4990) for replacement blades.

BLADE CARE

Like all power shears, this machine has high-carbon / high-chrome alloy tool steel blade with cutting edges on the bottom blade and two edges on the top blades are quickly and easily reversible when one edge is dull. The multiple shearing edges prolong blade life considerably.

- Never permit the blade to rub each other.
- Lubricate the blade with light oil when shearing stainless steel or galvanized material. Brush oil on the lower blade; the upper blade will pick up oil during the shearing cycle.
- Keep the blade sharp. Turn or change blades as soon as a burr is noted on the sheared stock. It is recommended that a spare set of blades be held in stock so as not to impair production during grinding.
- When all edges have been used, it will be necessary to have the blade ground. The blades should be ground so that the variation is no greater than 0.025mm within 3048mm and 0.05mm from the end to end.
- When re-installing re-ground blades, install shim stock under the lower edge to bring the blade up flush with the table.



To Rotate or Replace the Top Blade

⚠ CAUTION: Always wear proper eye protection with side shields, safety footwear, and leather gloves to protect from burrs and sharp edges. Keep hands and fingers clear of the shearing blade and clamping cylinders.

1. Raise the blade to the up position.
2. Shut down and lockout power to the machine.
3. Remove the yellow safety guard.
4. Remove the shadow wire to avoid breaking it, before changing the blade. Loosen the center bolts of both brackets and the outside setscrews to relieve tension on the wire. (fig. 5)

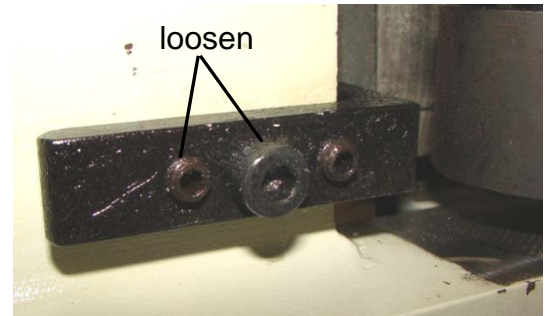

figure 5

5. **CAUTION: ALWAYS WEAR LEATHER GLOVES WHEN HANDLING THE BLADE.** Remove the capscrews and washers that hold the blade in place.
6. Turn the blade end for end if the other side is sharp, or replace the blade with a new one.
7. When the blade is in position, secure with the bolts and washers.
8. Re-attach the shadow wire. Adjust so that the wire is taut and as close to the blade as possible without touching.
9. Re-mount the yellow safety guard!
10. Set the blade gap arm to the 3/16" (4.76mm) setting, start the machine, and lower the top blade until it overlaps the bottom blade along the full length. The gap should measure .60mm or .023" along the full length. (The blades must be parallel.)
11. The blade gap adjustment setscrews are shown in (fig. 6). These were preset at the factory. **ADJUST ONLY IF ABSOLUTELY NECESSARY!**

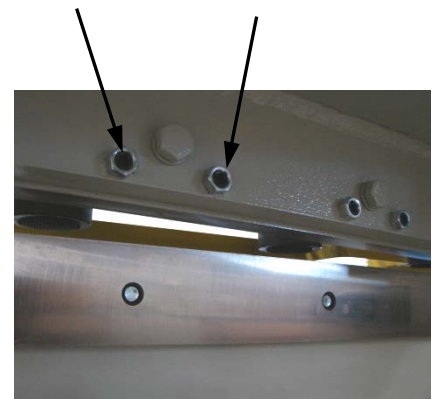

figure 6



To Rotate or Replace the Bottom Blade

⚠ CAUTION: Always wear proper eye protection with side shields, safety footwear, and leather gloves to protect from burrs and sharp edges. Keep hands and fingers clear of the shearing blade and clamping cylinders.

1. Raise the blade to the up position.
2. Shut down and lockout power to the machine.
3. Unbolt and remove the 2 ball transfer tables and the squaring arm. This will allow access to the rest of the bottom blade bolts. (fig. 7)
4. **CAUTION: ALWAYS WEAR LEATHER GLOVES WHEN HANDLING THE BLADE.** Remove the capscrews and washers from the front of the machine that hold the blade in place while the blade is removed from the back.
5. Turn the blade if you have not already used all four cutting edges, or replace the blade with a new one.
6. When in position, secure the blade with the bolts and washers.
7. Mount the 2 ball transfer tables and the squaring arm.
8. Set the blade gap arm to the 0.1875" (4.76mm) setting, start the machine, and lower the top blade until it overlaps the bottom blade along the full length. The gap should measure 0.023" (0.60mm) along the full length. (The blades must be parallel.)
9. There is no adjustment for the lower blade.



figure 7



KNIFE BAR WAYS ADJUSTMENT

The ram ways are adjustable to affect the wear that will occur during gears of service. The adjustment will only be required about every five (5) years, unless the shear is allowed to operate unlevelled which causes a twisting action and premature ways wear.

The proper running clearance is 0.0015"-0.0019" (0.038-0.05mm) and should be maintained at all times in order to get the maximum life from the blades & quality work from the shear.

The adjustment procedure is as follows:

1. Disconnect electrical power from the machine.
2. Loosen the lock nuts on the three square head set screw located at the front gib area of r.h. end heading.
3. Run center set screw in tight to take up excess clearance.
4. Run in the top and bottom screws until they strike the wear plate, the back off 1/16 of turn and tighten lock nuts.
5. Take off on the center set screw until it comes in line with the top and bottom screws, tighten lock nuts.



LUBRICATION AND MAINTENANCE



WARNING: Make sure the electrical disconnect is OFF before working on the machine.

Maintenance should be performed on a regular basis by qualified personnel.

Always follow proper safety precautions when working on or around any machinery.

Daily Maintenance

- Check daily for any unsafe conditions and fix immediately.
- Inspect the power plug and cord.
- Check the foot switch cable for any loosening or damage.
- Check hydraulic hoses and fittings for leakage.
- Keep area around machine clear of debris.
- Check that all nuts and bolts are properly tightened.

Weekly Maintenance

- Make sure proximity switches and limit switches are secure and adjusted properly.
- On a weekly basis clean the machine and the area around it.
- Lubricate threaded components and sliding devices.
- Apply rust inhibitive lubricant to all non-painted surfaces.



Note: *Proper maintenance can increase the life expectancy of your machine.*

Roller Lubrication

Lubricate the machines roller wheels monthly or as necessary using the grease gun provided. There are two grease fittings on each side, at the back of the shear. Also make sure there is adequate grease on the surfaces that the wheels ride on.

The blade gap adjustment chains and sprockets need to be oiled periodically. They are located between the rollers at each end of the machine.





Hydraulic Oil

The hydraulic oil is the primary medium for transmitting pressure and also must lubricate the running parts of the pump.

After installation of the machine and before machine startup, bring the oil level up to 90% of capacity. Verify that the ram is in the upper most position to prevent overfilling of the tank.

A shortage of hydraulic oil can cause hydraulic system breakdown and damage to major mechanical parts due to overheating.

1. Use hydraulic oil #46 or #68 SHELL BRAND or an equivalent with similar specifications. (Based upon location temperature and availability.)
2. Keep hydraulic reservoir filled to 90% of capacity.
3. DO NOT rely totally on the oil gauge as they can sometimes indicate an incorrect level reading. Do a visual inspection with the oil fill cap removed as well.
4. A shortage of hydraulic oil will cause hydraulic system breakdown to major mechanical components due to overheating.
5. Change the hydraulic oil every 12 months along with the oil filter.

Oil Change and Disposal

Change the oil in the hydraulic tank after the first 6 months, and every 12 months after that. Clean the filter basket located under the fill cap before refilling the tank.

Capacity of the oil tank is approx. 34 gallons. (128.7 liters) max. Required oil capacity is 27.5 gallons (104 liters).

Used oil products must be disposed of in a proper manner following your local regulations.

Air bleed for hydraulic hold down cylinders. If hold down cylinders don't all function the same, there might be air in the line.



Storing Machine for Extended Period of Time

If this machine is to be inactive for a long period of time, prepare the machine as follows:

- Disconnect the electrical supply from the power panel.
- Clean and grease the machine.
- Cover the machine.



HYDRAULIC SCHEMATIC

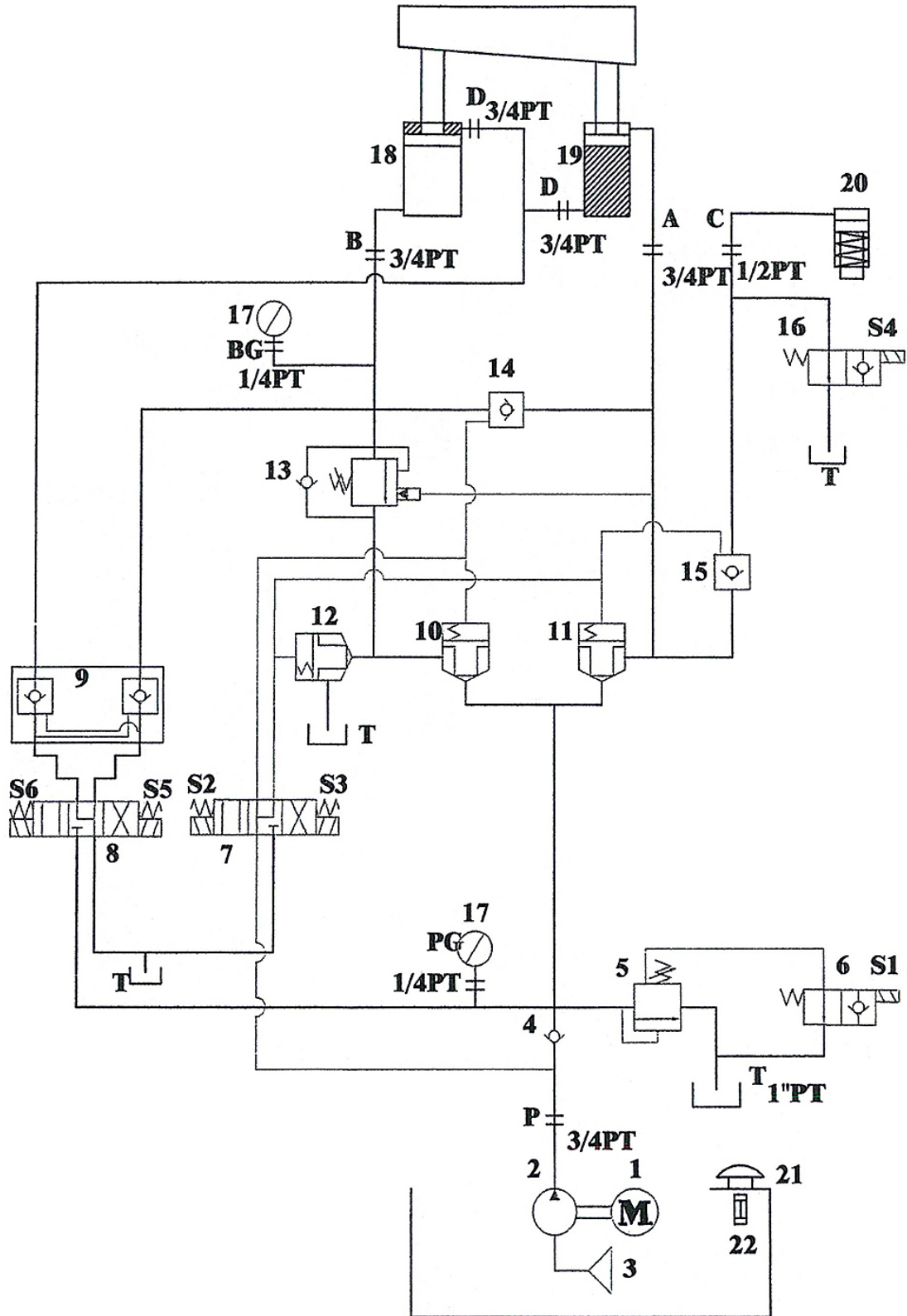



MANIFOLD BLOCK

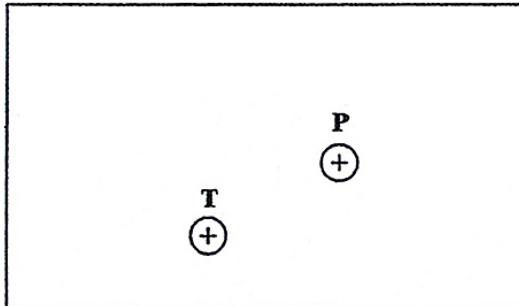
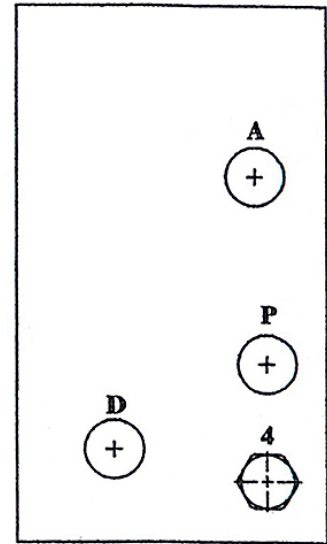
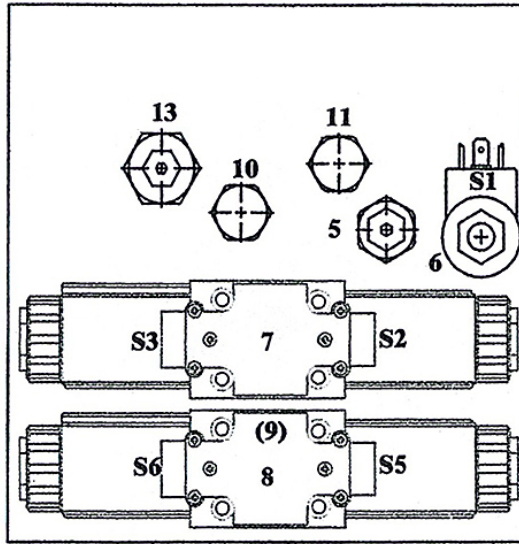
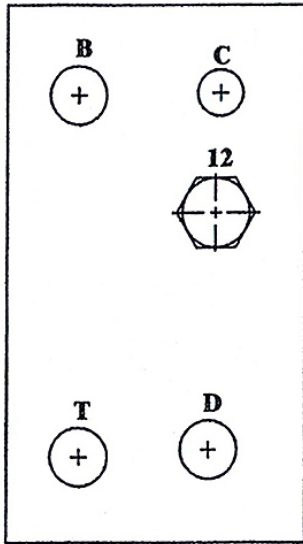
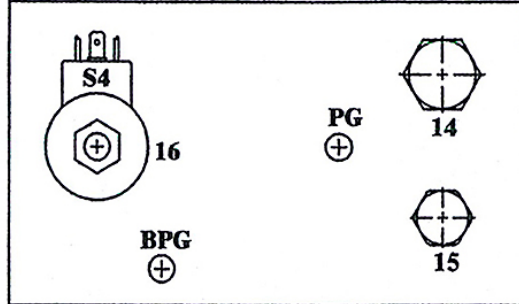

M	S	S1	S2	S3	S4	S5	S6
CUING, HOLD-DOWN DOWN		▲	▲		▲		
BLAND UP		▲		▲	▲		
HOLD-DOWN UP							
TOP-BLAND ANGLE BIG		▲				▲	
TOP-BLAND ANGLE SMALL		▲					▲



Hydraulic Component Identification

Item	Description	Part No.
1	Motor 15hp (11.2kw), 480V, 3ph, 60hz	HP*4P
2	Pump	VQ15-19-F-RRL-03
3	Strainer	MF-08
4	Check Valve	CV13A2050N
5	Relief Valve	RVCA LAN
6	SGREN-IN Solenoid Valve	SV08-21
7	Solenoid Valve	DG4V-3-7C
8	Solenoid Valve	DG4V-3-6C
9	Modular Pilot Operated Check Valve	MPC-02W
10	Logic Valve	LODC XDN
11	Logic Valve	LODC XDN
12	Logic Valve	LOFC XDN
13	Counter Balance Valve	CBEA LHN
14	Check Valve	COFA XCN
15	Check Valve	CODA XCN
16	SGREN-IN Solenoid Valve	SV10-23
17	Pressure Gauge	AT-63mm*280Kg
18	Hydraulic Cylinder	145mm dia.
19	Hydraulic Cylinder	130mm dia.
20	Hold-Down Cylinder	20mm dia.
21	Air Breather	HY-08
22	Oil Level w/Thermometer	LG-5A



ELECTRICAL ENCLOSURE BACK PANEL

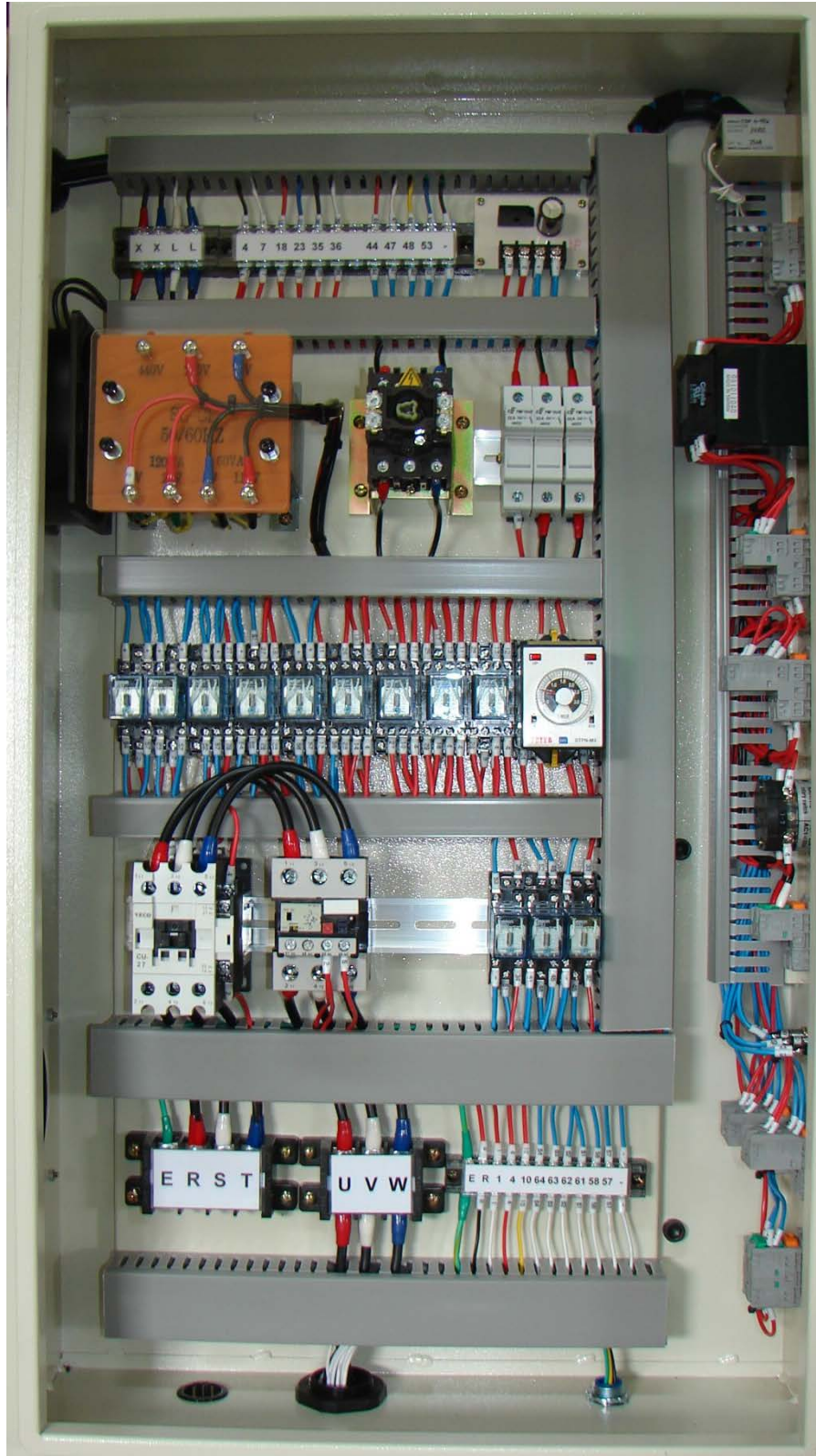



ELECTRICAL COMPONENT IDENTIFICATION

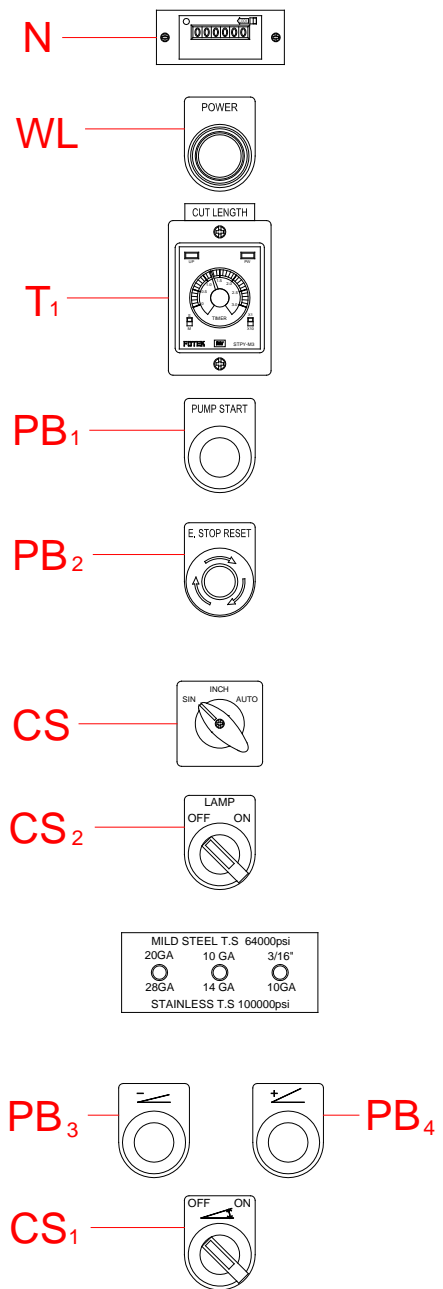
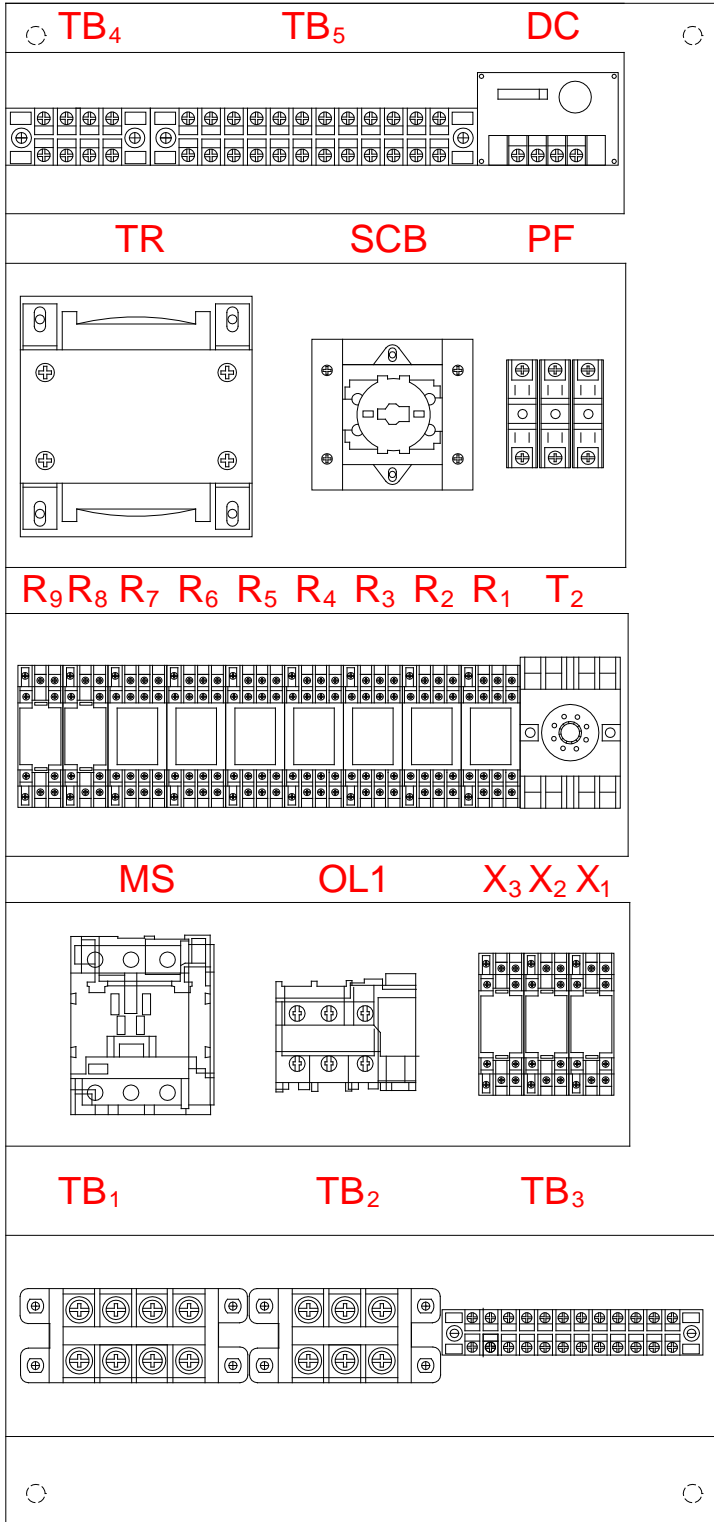

MILD STEEL T.S 64000psi		
20GA	10 GA	3/16"
28GA	14 GA	10GA
STAINLESS T.S 100000psi		



Electrical Parts List

Item	Description	Part No.
SCB	Main Switch	P1-32
MC	Magnetic Switch	CU-22
OL1	Over Circuit Relay	RHU-80KP 25A
TR	Transformer	1Ph, 240-480/110-24V
PF	Fuses	10 x 38mm @ 2A, 1A, 10A
DC	Power Supply	DC 24V 8A 2200uf
DCS	Power Supply	RS-25-24
RF	Fan	4" 110VAC
R1 - R7	Power Relay	MY-4 AC 24V RXM4LB1B7
R8, R9	Power Relay	MY-2 AC 24V RXM2LB1B7
X1 - X3	Power Relay	MY-2 DC 24V RXM2LB1BD
T1	On Delay Timer	SPTY-M3 5A 250V 3 SEC
T2	On Delay Timer	SPTN-M3 5A 250V 3 SEC
TB1	Transfer Bus	4P 30A
TB2	Transfer Bus	3P 30A
TB3	Transfer Bus	4P 30A
TB4	Transfer Bus	12P 30A
TB5	Transfer Bus	12P 30A
N	Counter	H7EC DC 24V
WL	Pilot Light	30, 24V, WHITE
PB1	Pushbutton	30, 1A1B RED (LOCK)
PB2	Pushbutton	30, 1A, 24V GREEN
PB3, PB4	Pushbutton	30, 1A1B
CS	Cam Switch	T-16EF48D1
CS1	Selector Switch	30, 1A
CS2	Selector Switch	30, 2A

Additional Electrical Components

Item	Description	Part No.
	LIMIT SWITCH	OMRON #D4V-8108Z
	PROXIMITY SWITCH	FOTEK #PM12-04N
	FLUORESCENT LAMP	FL 40G/38



ELECTRICAL SCHEMATIC (Sheet. 1)

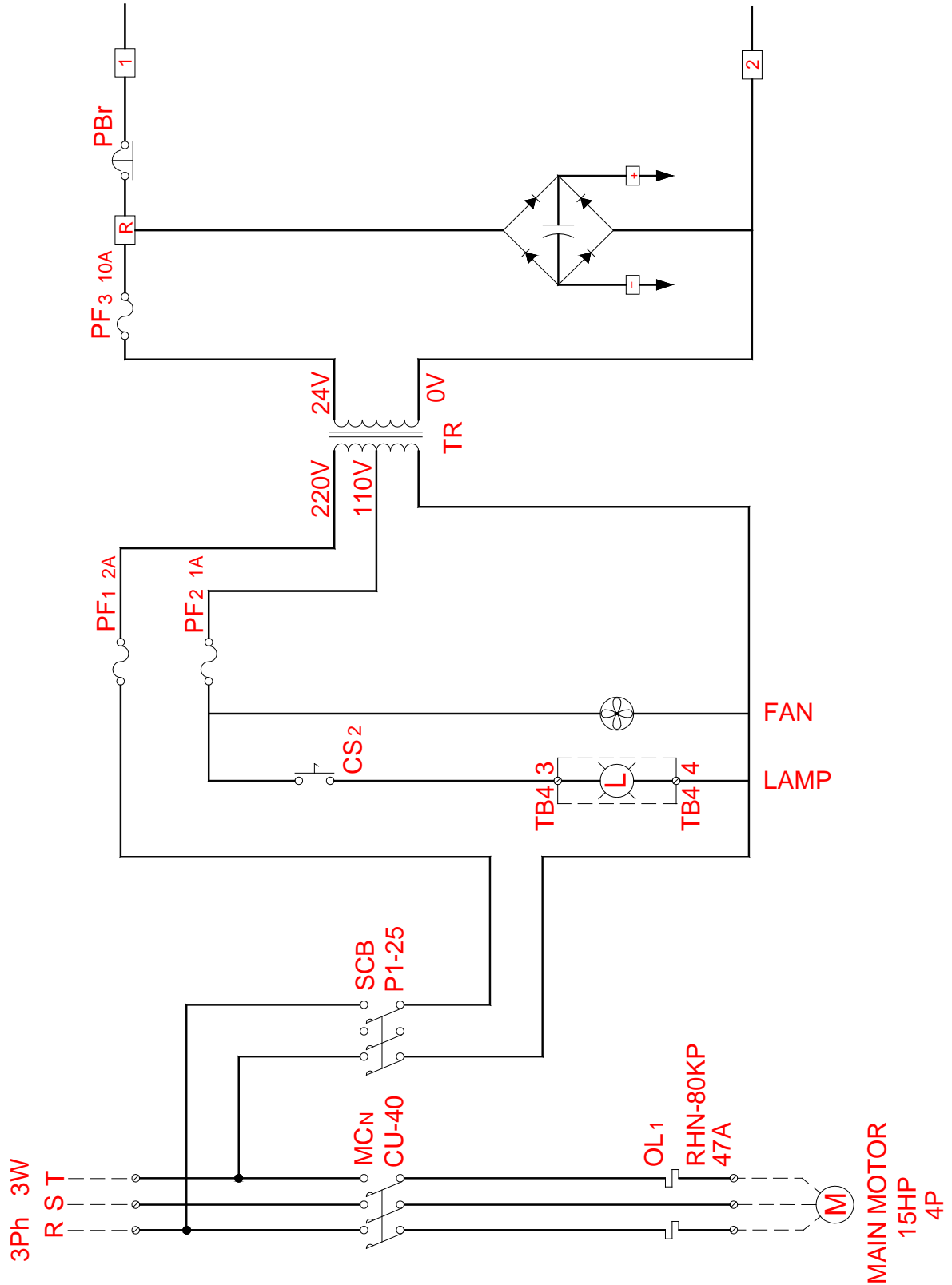



ELECTRICAL SCHEMATIC (Sheet 2)

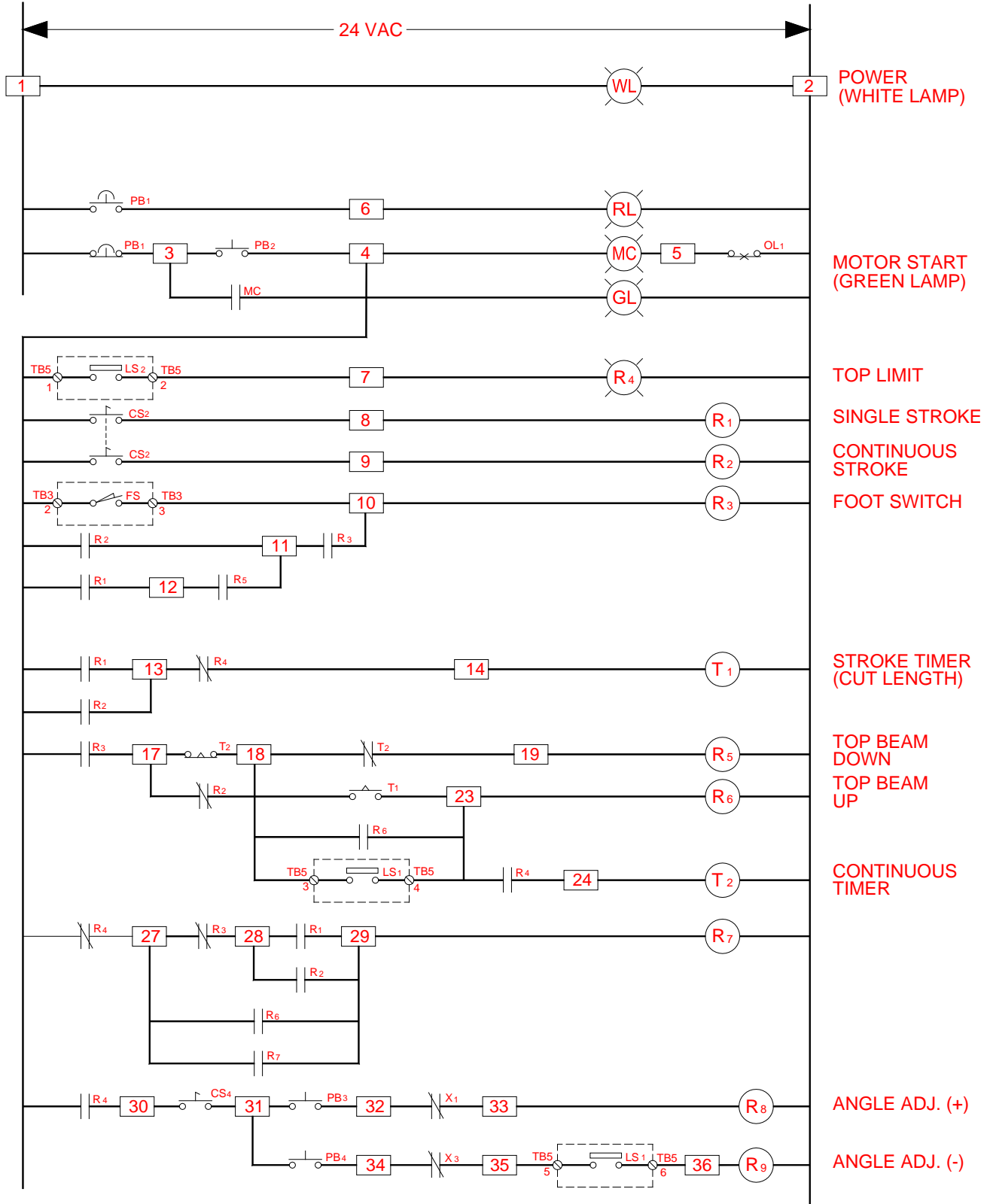



ELECTRICAL SCHEMATIC (Sheet 3)

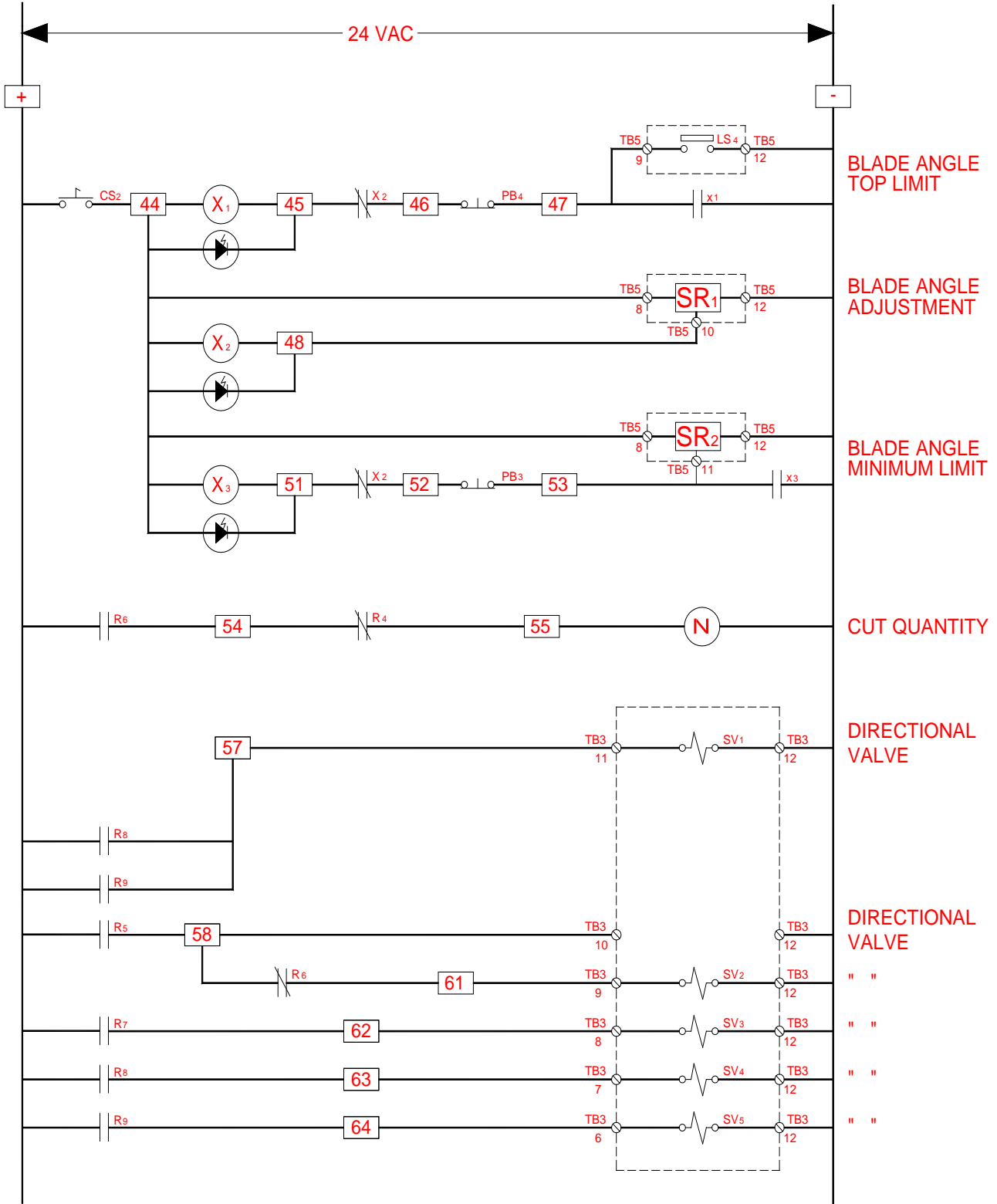



ELECTRICAL WIRE TERMINALS

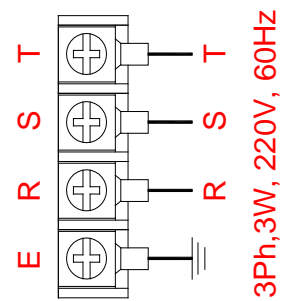
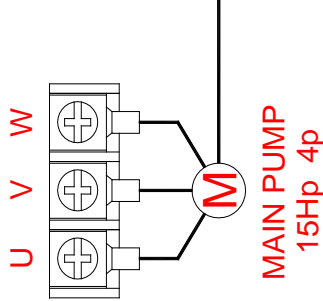
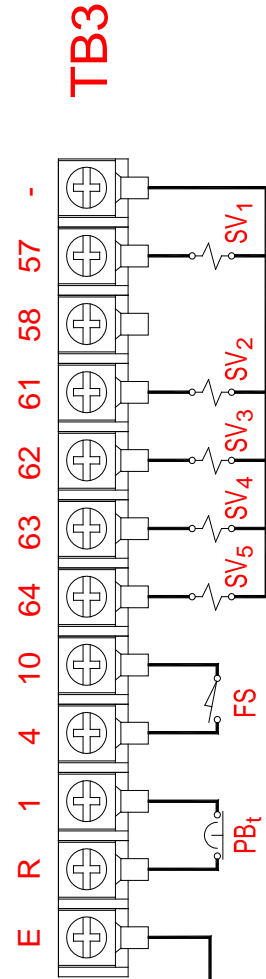
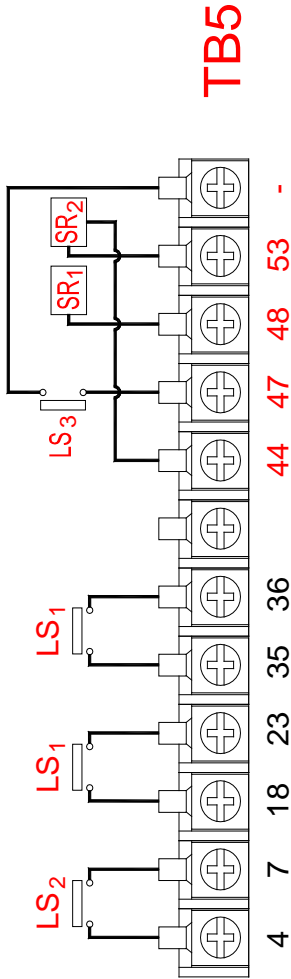



MECHANICAL REPLACEMENT PARTS

Item	Description	Part No.
1	Top sprocket	Hardened Teeth
2	Idler sprocket	20T Hardened Teeth
3	Bottom sprocket	Hardened Teeth
4	Roller chain	
5	Grease fitting	
6	Roller wheel	
7	Roller wheel bearing	
8	Bearing wheel	
9	Shadow wire	(by the foot)
10	Hold down rubber pad	SH8010

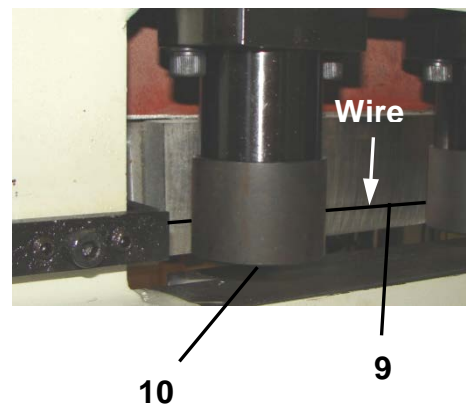
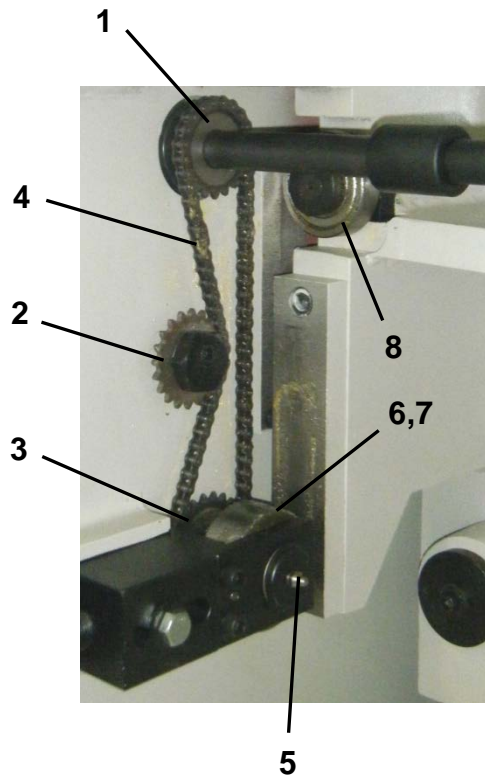

Shown with guards removed.
(For Identification Only!)



MAIN FRAME PARTS DIAGRAM

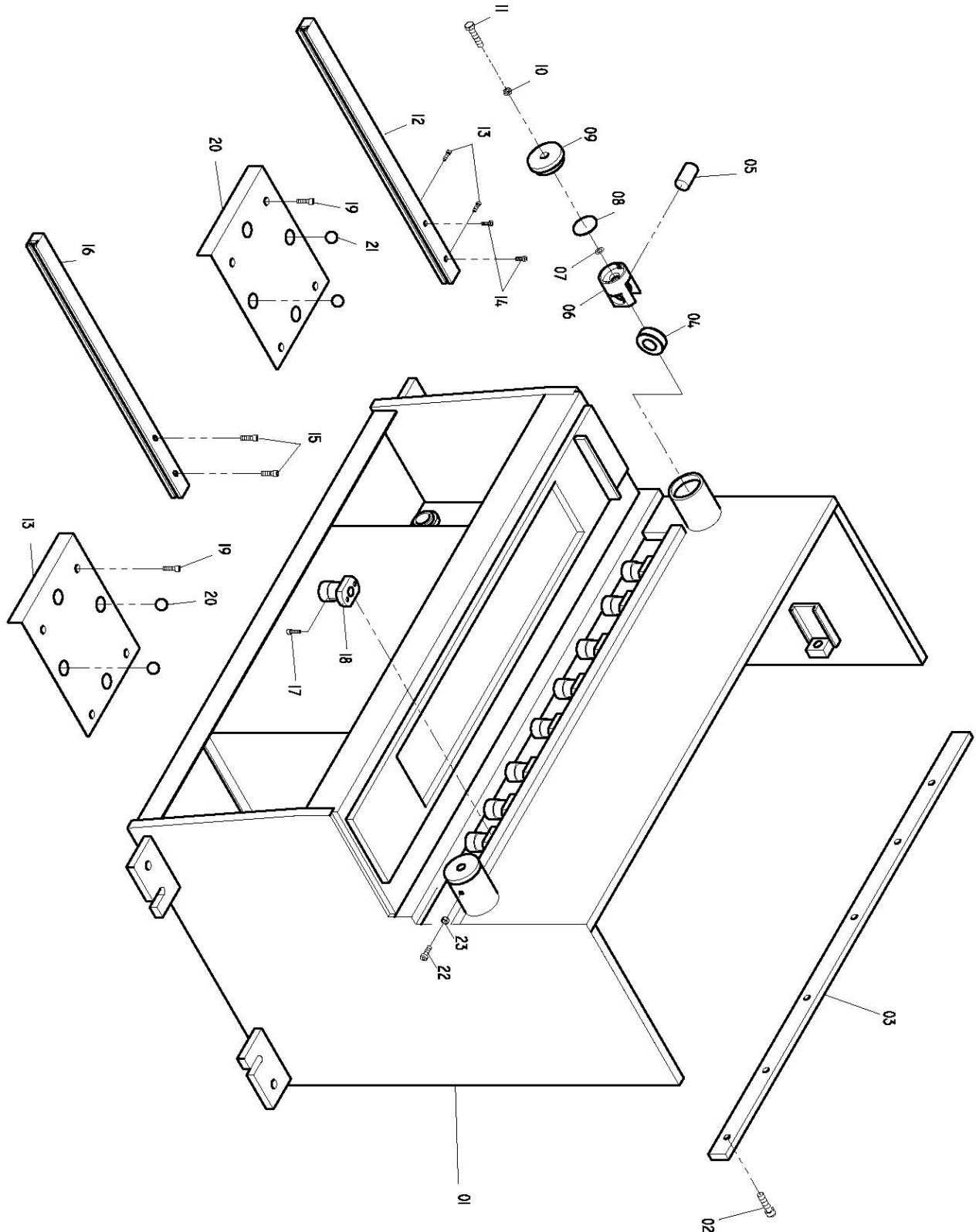

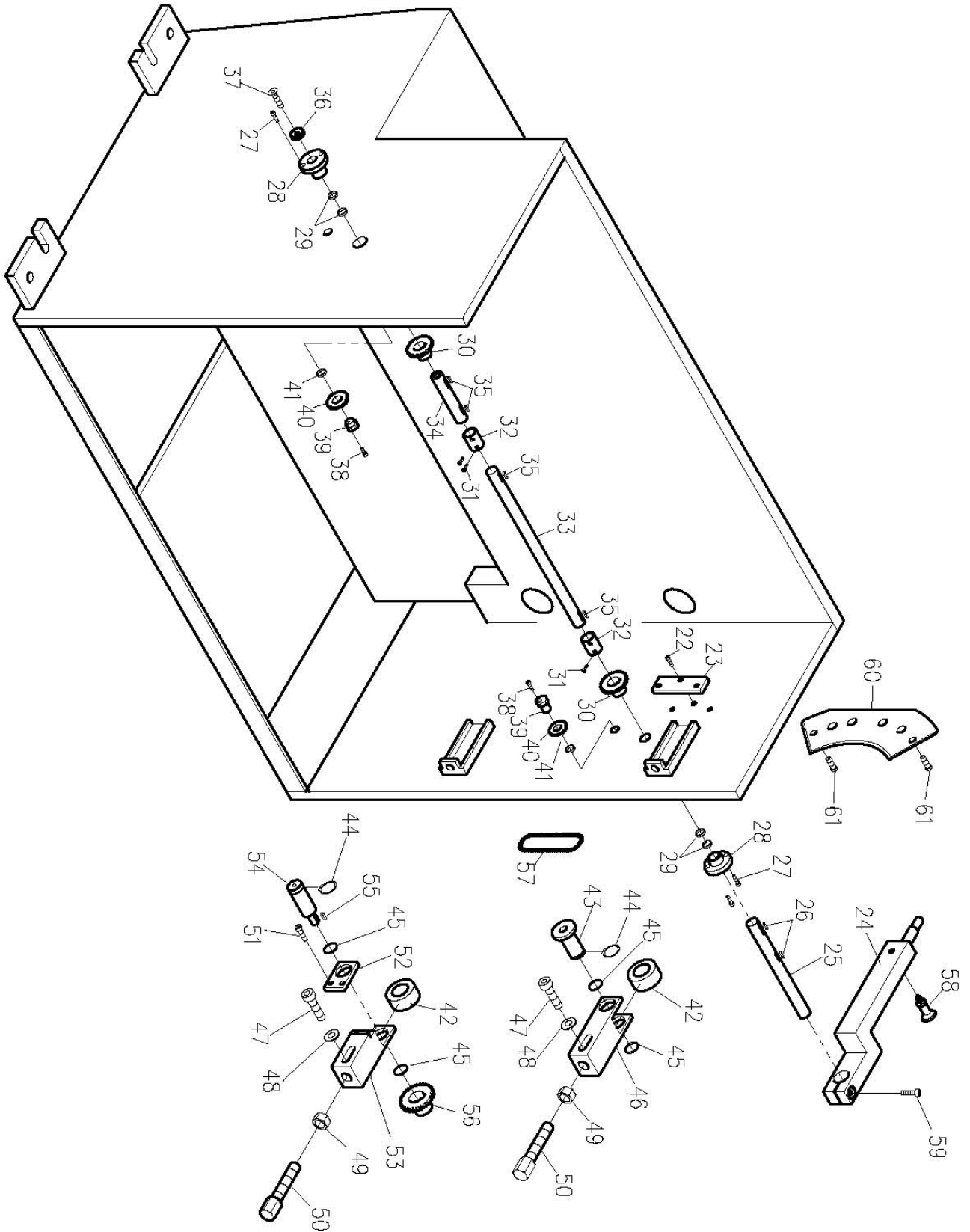

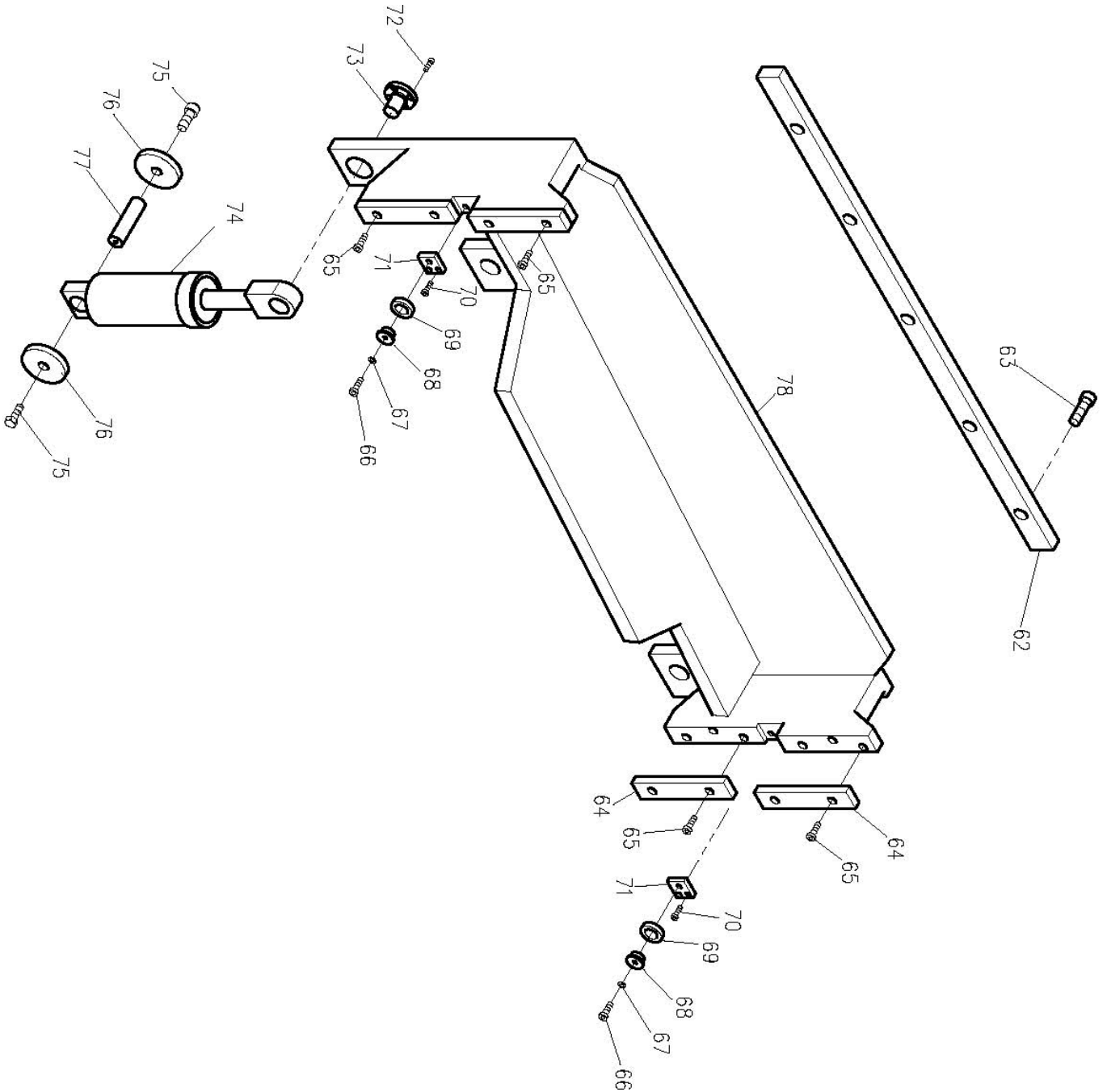



Main Frame Parts List

Item	Description
01	Bottom Beam Assy.
02	Screw
03	Upper Knife
04	Bearing
05	Bearing Shaft
06	Bearing Block
07	Washer
08	Division Plate
09	Bearing Block Cover
10	Nut
11	Screw
12	Side Gauge
13	Screw
14	Screw
15	Screw
16	Supporting Arm
17	Screw
18	Hold Down
19	Screw
20	Table Plate
21	Steel Ball
22	Screw
23	Nut
24	Knife Clearance Indicate Handle
25	Chain Sprocket Shaft
26	Key
27	Screw
28	Bearing Sleeve
29	Du
30	Chain Sprocket
31	Screw
32	Sleeve Coupling
33	Coupling Shaft



Item	Description
34	Chain Sprocket Shaft
35	Key
36	Shaft Filler Washer
37	Screw
38	Screw
39	Chain Adjuster
40	Chain Sprocket
41	Du
42	Bearing
43	Bearing Shaft
44	Snap Ring
45	Du
46	Adjusting Block
47	Screw
48	Washer
49	Nut
50	Adjusting Screw
61	Screw
62	Lower Knife
63	Screw
64	Wear Plate
65	Screw
66	Screw
67	Nut
68	Bearing Shaft
69	Bearing
70	Screw
71	Stool Plate
72	Screw
73	Cylinder Pin
74	Cylinder
75	Screw
76	Shaft Filler Washer
77	Cylinder Pin



HYDRAULIC CYLINDER-PARTS DIAGRAM

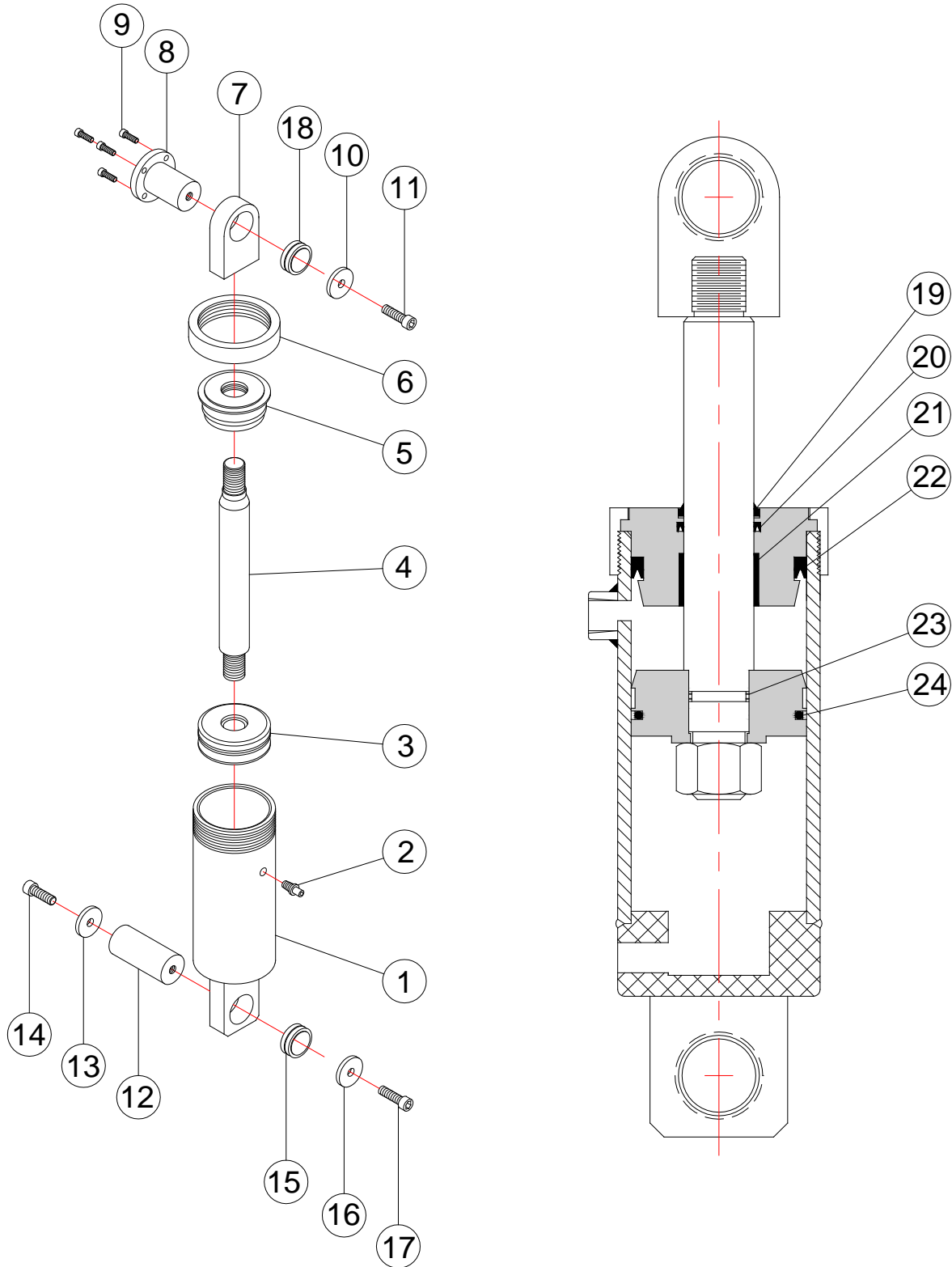



Hydraulic Cylinder Parts List

Item	Description
1	Cylinder Body
2	Air Bleed Screw (large cylinder only)
3	Piston
4	Inner Rod
5	End Gland
6	Nut
7	Clevis (Rod End)
8	Link Shaft (Up)
9	Socket Head Screw 5/16 x .75" Long
10	Washer
11	Socket Head Screw 3/8 x 1.00" Long
12	Link Shaft (Down)
13	Washer
14	Socket Head Screw 3/8" x 1.00" Long
15	Bearing (Fish Eye Type)
16	Washer
17	Socket Head Screw 3/8" x 1.00" Long
18	Bearing (Fish Eye Type)
19	Wiper
20	Rod Seal
21	Wear Ring
22	Rod Seal
23	"O"-Ring
24	Piston Seal



HOLD DOWN CYLINDER PARTS DIAGRAM

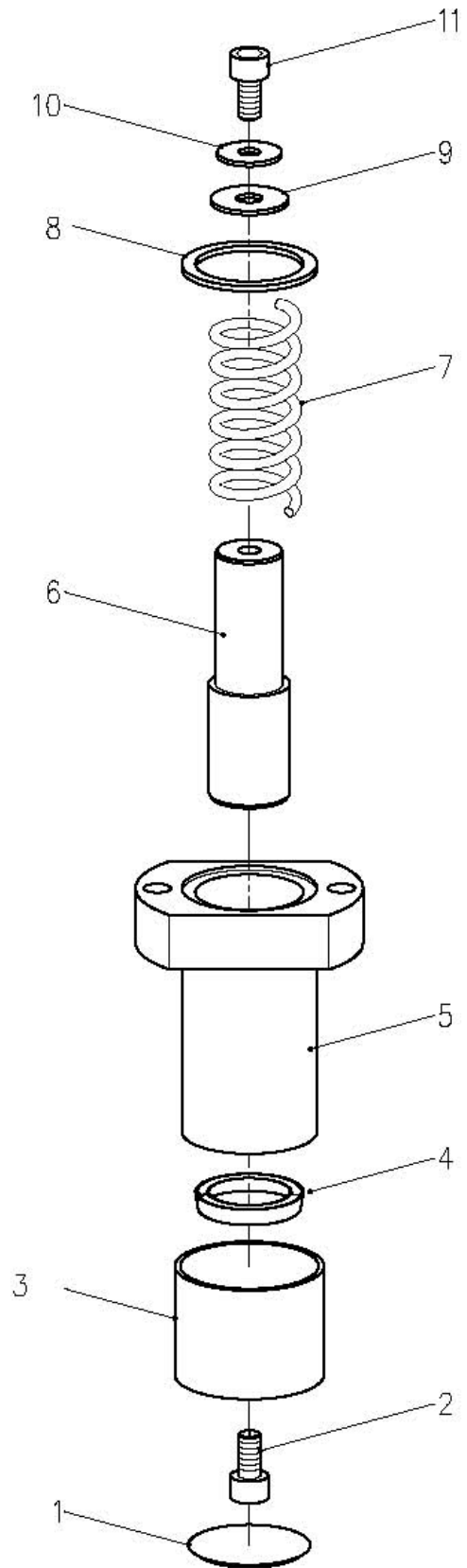

Hold Down Cylinder Parts List

Item	Description
01	Rubber Pad
02	Socket Head Screw 5/16 x .75" Long
03	Cover
04	Oil Seal
05	Cylinder Pipe
06	Piston Rod
07	Spring
08	Dual Backup Ring
09	Washer
10	Washer
11	Socket Head Screw 5/16 x .75" Long



BACK GAUGE PARTS DIAGRAM

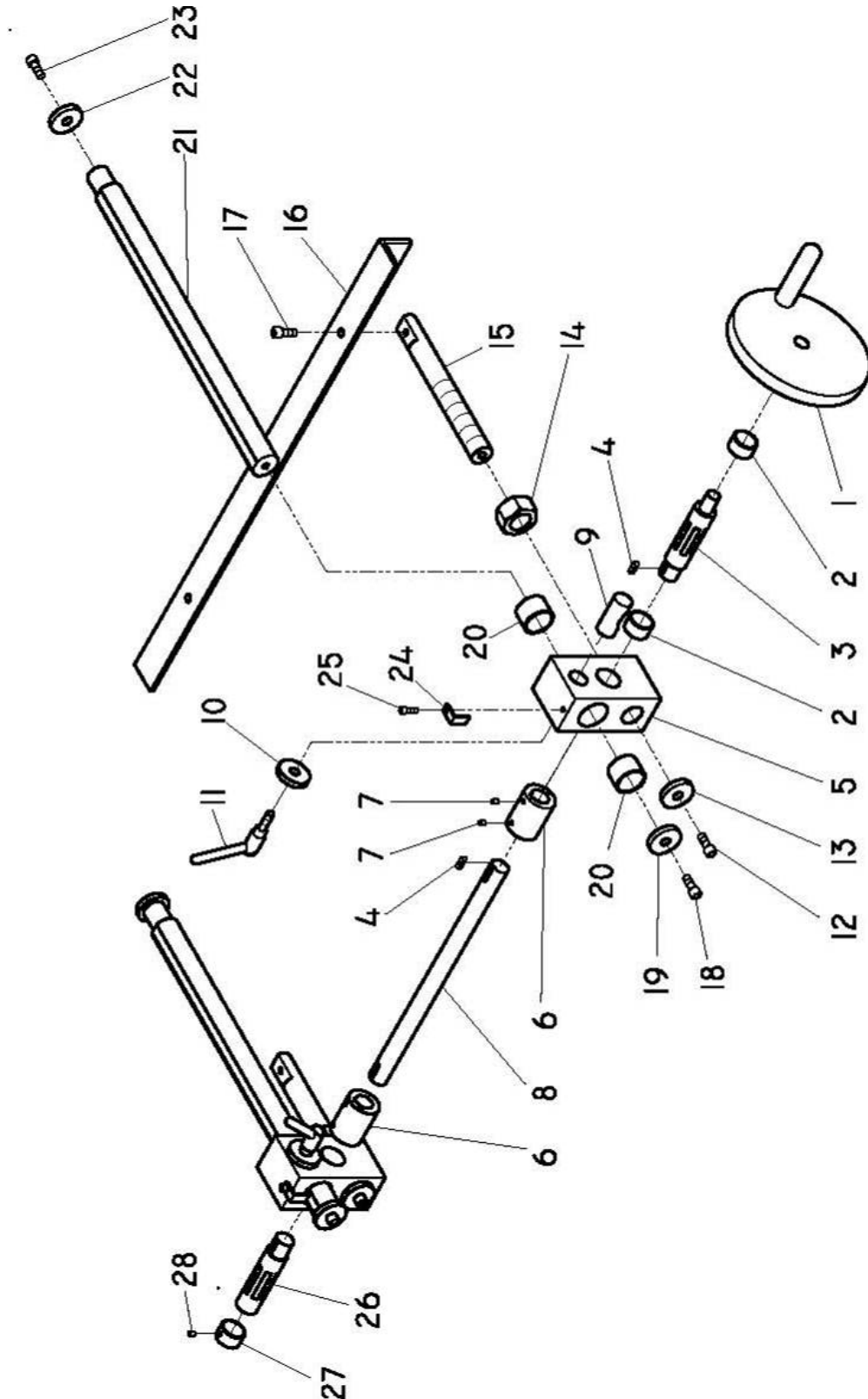



Back Gauge Parts List

Item	Description
1	Hand Wheel
2	Bearing
3	Rack Wheel-Right Side
4	Key
5	Rack Block
6	Sleeve Coupling
7	Set Screw
8	Coupling Shaft
9	Locking Shaft
10	Washer
11	Plastic Handle
12	Slotted Head Screw
13	Shaft Filler Washer
14	Nut
15	Adjusting Rod
16	Angle Stopper
17	Screw
18	Screw
19	Shaft Filler Washer
20	Bearing
21	Rack Rod
22	Shaft Filler Washer
23	Screw
24	Dial Indicator
25	Screw
26	Rack Wheel - Left Side
27	Collar
28	Screw



TROUBLESHOOTING



WARNING: Make sure the electrical disconnect is **OFF** before working on the machine.

SYMPTOM	POSSIBLE CAUSE (S)	CORRECTIVE ACTION
Motor Does Not Start	No power.	Check the power source.
	Disconnect switch not turned on.	Turn the switch to ON position.
	Emergency button not reset.	Release the emergency buttons by turning the knob to the right.
	Motor damaged.	Replace motor.
	Motor power cable not connected properly.	Check the cable connection and reconnect cable. Change cable if worn out.
	Motor circuit breaker tripped.	Reset the breaker to ON position.
	Fuse blown.	Check and replace fuse(s).
	Magnetic switch damaged or burned out.	Replace switch.
Motor is ON, but machine will not move.	Transformer damaged.	Replace transformer.
	Motor turning in the wrong direction.	Turn machine OFF. Change any two of the three power source wires. Recheck motor direction.
	Not enough hydraulic oil.	Check oil level and add oil if necessary.
	Solenoid valve stuck.	Clean or replace valve.
	Solenoid valve coil burned out.	Replace solenoid valve.
	Foot pedal not sending signal.	Check pedal and replace switch if necessary.
	Relay stuck or burned out.	Replace relay.
Limit switch not set at correct position.	Adjust the limit switch for proper stroke travel setting.	



SYMPTOM	POSSIBLE CAUSE (S)	CORRECTIVE ACTION
<p>Machine moves, but cannot reach capacity.</p>	<p>Relief valve not set correctly.</p> <p>Relief valve damaged.</p> <p>Pump damaged.</p> <p>Internal cylinder leak.</p> <p>Pilot check valve not set correctly.</p>	<p>Check hydraulic pressure and adjust relief valve (tighten to increase pressure).</p> <p>Replace relief valve.</p> <p>Replace pump</p> <p>Contact dealer for service.</p> <p>Adjust the correct pressure setting of the valve.</p>
<p>Excessive hydraulic noise</p>	<p>Motor turning in wrong direction.</p> <p>Pump worn out.</p> <p>Not enough oil.</p> <p>Ball valves on hydraulic tank are closed.</p>	<p>Turn machine OFF. Change any two of the three power source wires. Re-check motor direction.</p> <p>Replace pump.</p> <p>Check oil level and add oil if necessary.</p> <p>Open valves to allow oil flow.</p>
<p>Hydraulic hold downs do not work</p>	<p>Ball valve is shut off.</p>	<p>Rotate handle 90° counterclockwise (ccw) to open.</p>

NOTES



BAILEIGH INDUSTRIAL, INC. 1625 DUFEEK DRIVE MANITOWOC, WI 54220

PHONE: 920. 684. 4990 FAX: 920. 684. 3944

www.baileigh.com

BAILEIGH INDUSTRIAL, INC. 1455 S. CAMPUS AVENUE ONTARIO, CA 91761

PHONE: 920. 684. 4990 FAX: 920. 684. 3944

BAILEIGH INDUSTRIAL LTD. UNIT D SWIFT POINT

SWIFT VALLEY INDUSTRIAL ESTATE, RUGBY

WEST MIDLANDS, CV21 1QH UNITED KINGDOM

PHONE: +44 (0)24 7661 9267 FAX: +44 (0)24 7661 9276

WWW.BAILEIGH.CO.UK