



OPERATOR'S MANUAL



VARIABLE SPEED WOOD LATHE MODEL: WL-1847VS

Baileigh Industrial Holdings LLC,
P.O. Box 531
Manitowoc, WI 54221-0531
Phone: 920.684.4990
Fax: 920.684.3944
sales@baileigh.com

REPRODUCTION OF THIS MANUAL IN ANY FORM WITHOUT WRITTEN APPROVAL OF BAILEIGH INDUSTRIAL HOLDINGS LLC, IS PROHIBITED. Baileigh Industrial Holdings LLC, does not assume and hereby disclaims any liability for any damage or loss caused by an omission or error in this Operator's Manual, resulting from accident, negligence, or other occurrence.

Table of Contents

THANK YOU & WARRANTY	1
INTRODUCTION.....	3
GENERAL NOTES.....	3
SAFETY INSTRUCTIONS	4
SAFETY PRECAUTIONS	7
Dear Valued Customer:.....	7
TECHNICAL SPECIFICATIONS	10
TECHNICAL SUPPORT	10
UNPACKING AND CHECKING CONTENTS.....	11
Cleaning	11
ASSEMBLY.....	13
TRANSPORTING AND LIFTING	14
INSTALLATION.....	14
GETTING TO KNOW YOUR MACHINE	16
ELECTRICAL.....	18
Power cord connection:	19
WIRING DIAGRAM.....	20
CHANGING SPEEDS	21
OPERATION.....	21
LATHE TOOLS.....	21
HOW TO TURN SPINDLES	22
CENTERING THE WORK	22
TOOL REST POSITION	23
ROUGHING A CYLINDER.....	24
POSITION OF HANDS.....	25
SMOOTHING A CYLINDER	25
OWNER MADE OPTIONS.....	26
MAINTENANCE.....	27
TROUBLESHOOTING	28
STAND AND BED ASSEMBLY.....	29
Parts List	30
HEADSTOCK ASSEMBLY	31
Parts List	32



THANK YOU & WARRANTY

Thank you for your purchase of a machine from Baileigh Industrial Holdings LLC. We hope that you find it productive and useful to you for a long time to come.

Inspection & Acceptance. Buyer shall inspect all Goods within ten (10) days after receipt thereof. Buyer's payment shall constitute final acceptance of the Goods and shall act as a waiver of the Buyer's rights to inspect or reject the goods unless otherwise agreed. If Buyer rejects any merchandise, Buyer must first obtain a Returned Goods Authorization ("RGA") number before returning any goods to Seller. Goods returned without a RGA will be refused. Seller will not be responsible for any freight costs, damages to goods, or any other costs or liabilities pertaining to goods returned without an RGA. Seller shall have the right to substitute a conforming tender. Buyer will be responsible for all freight costs to and from Buyer and repackaging costs, if any, if Buyer refuses to accept shipment. If Goods are returned in unsalable condition, Buyer shall be responsible for full value of the Goods. Buyer may not return any special-order Goods. Any Goods returned hereunder shall be subject to a restocking fee equal to 30% of the invoice price.

Specifications. Seller may, at its option, make changes in the designs, specifications or components of the Goods to improve the safety of such Goods, or if in Seller's judgment, such changes will be beneficial to their operation or use. Buyer may not make any changes in the specifications for the Goods unless Seller approves of such changes in writing, in which event Seller may impose additional charges to implement such changes.

Limited Warranty. Seller warrants to the original end-user that the Goods manufactured or provided by Seller under this Agreement shall be free of defects in material or workmanship for a period of twelve (12) months from the date of purchase, provided that the Goods are installed, used, and maintained in accordance with any instruction manual or technical guidelines provided by the Seller or supplied with the Goods, if applicable. The original end-user must give written notice to Seller of any suspected defect in the Goods prior to the expiration of the warranty period. The original end-user must also obtain a RGA from Seller prior to returning any Goods to Seller for warranty service under this paragraph. Seller will not accept any responsibility for Goods returned without a RGA. The original end-user shall be responsible for all costs and expenses associated with returning the Goods to Seller for warranty service. In the event of a defect, Seller, at its sole option, shall repair or replace the defective Goods or refund to the original end-user the purchase price for such defective Goods. Goods are not eligible for replacement or return after a period of 10 days from date of receipt. The foregoing warranty is Seller's sole obligation, and the original end-user's exclusive remedy, with regard to any defective Goods. This limited warranty does not apply to: (a) die sets, tooling, and saw blades; (b) periodic or routine maintenance and setup, (c) repair or replacement of the Goods due to normal wear and tear, (d) defects or damage to the Goods resulting from misuse, abuse, neglect, or accidents, (e) defects or damage to the Goods resulting from improper or unauthorized alterations, modifications, or changes; and (f) any Goods that has not been installed and/or maintained in accordance with the instruction manual or technical guidelines provided by Seller.

EXCLUSION OF OTHER WARRANTIES. THE FOREGOING LIMITED WARRANTY IS IN LIEU OF ALL OTHER WARRANTIES, EXPRESS OR IMPLIED. ANY AND ALL OTHER EXPRESS, STATUTORY OR IMPLIED WARRANTIES, INCLUDING BUT NOT LIMITED TO, ANY WARRANTY OF MERCHANTABILITY OR FITNESS FOR ANY PARTICULAR PURPOSE ARE EXPRESSLY DISCLAIMED. NO WARRANTY IS MADE WHICH EXTENDS BEYOND THAT WHICH IS EXPRESSLY CONTAINED HEREIN.

Limitation of Liability. IN NO EVENT SHALL SELLER BE LIABLE TO BUYER OR ANY OTHER PARTY FOR ANY INCIDENTAL, CONSEQUENTIAL OR SPECIAL DAMAGES (INCLUDING, WITHOUT LIMITATION, LOST PROFITS OR DOWN TIME) ARISING FROM OR IN MANNER CONNECTED WITH THE GOODS, ANY BREACH BY SELLER OR ITS AGENTS OF THIS AGREEMENT, OR ANY OTHER CAUSE WHATSOEVER, WHETHER BASED ON CONTRACT, TORT OR ANY OTHER THEORY OF LIABILITY. BUYER'S REMEDY WITH RESPECT TO ANY CLAIM ARISING UNDER THIS AGREEMENT IS STRICTLY LIMITED TO NO MORE THAN THE AMOUNT PAID BY THE BUYER FOR THE GOODS.



Force Majeure. Seller shall not be responsible for any delay in the delivery of, or failure to deliver, Goods due to causes beyond Seller's reasonable control including, without limitation, acts of God, acts of war or terrorism, enemy actions, hostilities, strikes, labor difficulties, embargoes, non-delivery or late delivery of materials, parts and equipment or transportation delays not caused by the fault of Seller, delays caused by civil authorities, governmental regulations or orders, fire, lightening, natural disasters or any other cause beyond Seller's reasonable control. In the event of any such delay, performance will be postponed by such length of time as may be reasonably necessary to compensate for the delay.

Installation. If Buyer purchases any Goods that require installation, Buyer shall, at its expense, make all arrangements and connections necessary to install and operate the Goods. Buyer shall install the Goods in accordance with any Seller instructions and shall indemnify Seller against any and all damages, demands, suits, causes of action, claims and expenses (including actual attorneys' fees and costs) arising directly or indirectly out of Buyer's failure to properly install the Goods.

Work By Others; Safety Devices. Unless agreed to in writing by Seller, Seller has no responsibility for labor or work performed by Buyer or others, of any nature, relating to design, manufacture, fabrication, use, installation or provision of Goods. Buyer is solely responsible for furnishing and requiring its employees and customers to use all safety devices, guards and safe operating procedures required by law and/or as set forth in manuals and instruction sheets furnished by Seller. Buyer is responsible for consulting all operator manuals, ANSI or comparable safety standards, OSHA regulations and other sources of safety standards and regulations applicable to the use and operation of the Goods.

Remedies. Each of the rights and remedies of Seller under this Agreement is cumulative and in addition to any other or further remedies provided under this Agreement or at law or equity.

Attorney's Fees. In the event legal action is necessary to recover monies due from Buyer or to enforce any provision of this Agreement, Buyer shall be liable to Seller for all costs and expenses associated therewith, including Seller's actual attorney fees and costs.

Governing Law/Venue. This Agreement shall be construed and governed under the laws of the State of Wisconsin, without application of conflict of law principles. Each party agrees that all actions or proceedings arising out of or in connection with this Agreement shall be commenced, tried, and litigated only in the state courts sitting in Manitowoc County, Wisconsin or the U.S. Federal Court for the Eastern District of Wisconsin. Each party waives any right it may have to assert the doctrine of "forum non conveniens" or to object to venue to the extent that any proceeding is brought in accordance with this section. Each party consents to and waives any objection to the exercise of personal jurisdiction over it by courts described in this section. Each party waives to the fullest extent permitted by applicable law the right to a trial by jury.

SUMMARY OF RETURN POLICY.

- 10 Day acceptance period from date of delivery. Damage claims and order discrepancies will not be accepted after this time.
- You must obtain a Baileigh issued RGA number PRIOR to returning any materials.
- Returned materials must be received at Baileigh in new condition and in original packaging.
- Altered items are not eligible for return.
- Buyer is responsible for all shipping charges.
- A 30% re-stocking fee applies to all returns.

Baileigh Industrial Holdings LLC makes every effort to ensure that our posted specifications, images, pricing and product availability are as correct and timely as possible. We apologize for any discrepancies that may occur. Baileigh Industrial Holdings LLC reserves the right to make any and all changes deemed necessary in the course of business including but not limited to pricing, product specifications, quantities, and product availability.

For Customer Service & Technical Support:

Please contact one of our knowledgeable Sales and Service team members at:
(920) 684-4990 or e-mail us at sales@baileighindustrial.com



INTRODUCTION

The quality and reliability of the components assembled on a Baileigh Industrial Holdings LLC machine guarantee near perfect functioning, free from problems, even under the most demanding working conditions. However, if a situation arises, refer to the manual first. If a solution cannot be found, contact the distributor where you purchased our product. Make sure you have the serial number and production year of the machine (stamped on the nameplate). For replacement parts refer to the assembly numbers on the parts list drawings.

Our technical staff will do their best to help you get your machine back in working order.

In this manual you will find: (when applicable)

- Safety procedures
- Correct installation guidelines
- Description of the functional parts of the machine
- Capacity charts
- Setup and start-up instructions
- Machine operation
- Scheduled maintenance
- Parts lists

GENERAL NOTES

After receiving your equipment remove the protective container. Do a complete visual inspection, and if damage is noted, **photograph it for insurance claims** and contact your carrier at once, requesting inspection. Also contact Baileigh Industrial Holdings LLC and inform them of the unexpected occurrence. Temporarily suspend installation.

Take necessary precautions while loading / unloading or moving the machine to avoid any injuries.

Your machine is designed and manufactured to work smoothly and efficiently. Following proper maintenance instructions will help ensure this. Try and use original spare parts, whenever possible, and most importantly; **DO NOT** overload the machine or make any unauthorized modifications.



Note: *This symbol refers to useful information throughout the manual.*



IMPORTANT

PLEASE READ THIS OPERATORS MANUAL CAREFULLY

It contains important safety information, instructions, and necessary operating procedures. The continual observance of these procedures will help increase your production and extend the life of the equipment.

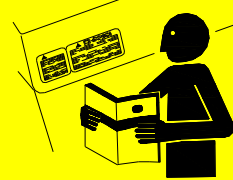

SAFETY INSTRUCTIONS

LEARN TO RECOGNIZE SAFETY INFORMATION

This is the safety alert symbol. When you see this symbol on your machine or in this manual, **BE ALERT TO THE POTENTIAL FOR PERSONAL INJURY!**



Follow recommended precautions and safe operating practices.

UNDERSTAND SIGNAL WORDS

A signal word – **DANGER**, **WARNING**, or **CAUTION** – is used with the safety alert symbol. **NOTICE**, which is not related to personal injury, is used without a symbol.

DANGER: Indicates a hazardous situation which, if not avoided, will result in death or serious injury.

WARNING: Indicates a hazardous situation which, if not avoided, could result in death or serious injury.

CAUTION: Indicates a hazardous situation which, if not avoided, could result in minor or moderate injury.

NOTICE: Indicates a situation which, if not avoided, could result in property damage.

DANGER

WARNING

CAUTION

NOTICE



SAVE THESE INSTRUCTIONS.
Refer to them often and use them to instruct others.



PROTECT EYES

Wear safety glasses or suitable eye protection when working on or around machinery.

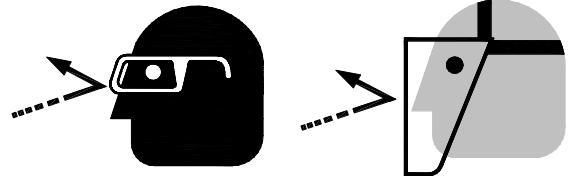

PROTECT AGAINST NOISE

Prolonged exposure to loud noise can cause impairment or loss of hearing. Wear suitable hearing protective devices such as ear muffs or earplugs to protect against objectionable or uncomfortable loud noises.

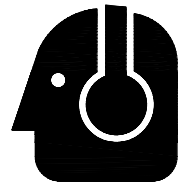

DUST HAZARD

Wear appropriate dust mask. Dust created while using machinery can cause cancer, birth defects, and long term respiratory damage. Be aware of the dust hazards associated with all types of materials.

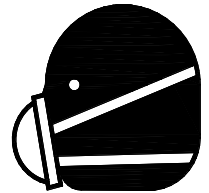

DUST PARTICLES AND IGNITION SOURCES

DO NOT operate the table saw in areas where explosion risks are high. Such areas include locations near pilot lights, open flames, or other ignition sources.

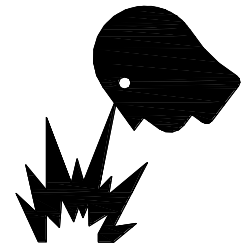

ROTATING TOOL HAZARD

Keep hands and body clear while operating. Rotating chuck can cut, dismember, snag, and entrap. Flying chips, splinters, and other particles can cause serious injury or death.





HIGH VOLTAGE

USE CAUTION IN HIGH VOLTAGE AREAS. DO NOT assume the power to be off.
FOLLOW PROPER LOCKOUT PROCEDURES.

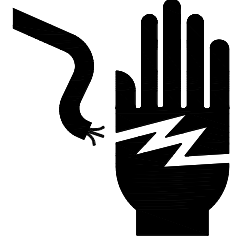

Power Switch with Lock Out

In the event of incorrect operation or dangerous conditions, the machine can be stopped immediately by pressing the Power Switch paddle downward. Remove the yellow lock key to prevent the machine from starting.



Note: Resetting the Power Switch WILL start the machine.



CALIFORNIA PROPOSITION 65

WARNING: Cancer and Reproductive Harm.
www.P65Warnings.ca.gov





SAFETY PRECAUTIONS



Wood working can be dangerous if safe and proper operating procedures are not followed. As with all machinery, there are certain hazards involved with the operation of the product. Using the machine with respect and caution will considerably lessen the possibility of personal injury. However, if normal safety precautions are overlooked or ignored, personal injury to the operator may result.

Safety equipment such as guards, push sticks, hold-downs, feather boards, goggles, dust masks and hearing protection can reduce your potential for injury. But even the best guard will not make up for poor judgment, carelessness or inattention. **Always use common sense** and exercise **caution** in the workshop. If a procedure feels dangerous, don't try it.

REMEMBER: Your personal safety is your responsibility.



WARNING: FAILURE TO FOLLOW THESE RULES MAY RESULT IN SERIOUS PERSONAL INJURY

Dear Valued Customer:

- All Baileigh woodworking machines should be used only for their intended use.
- Baileigh does not recommend or endorse making any modifications or alterations to a Baileigh machine. Modifications or alterations to a machine may pose a substantial risk of injury to the operator or others and may do substantial damage to the machine.
- Any modifications or alterations to a Baileigh machine will invalidate the machine's warranty.

Please enjoy your Baileigh machine!Please enjoy it SAFELY!

1. **FOR YOUR OWN SAFETY, READ INSTRUCTION MANUAL BEFORE OPERATING THE MACHINE.** Learn the machine's application and limitations as well as the specific hazards.
2. Only trained and qualified personnel should operate this machine.
3. **Make Sure** lathe is located on a flat stable surface.
4. **Make sure guards are in place and in proper working order before operating machinery.**
5. **Use eye protection.** Always wear ISO approved protective eye wear when operating machinery. Wear a full-face shield if you are producing filings or chips. Eye wear shall be impact resistant, protective safety glasses with side shields which comply with ANSI Z87.1 specification. Use of eye wear which does not comply with ANSI Z87.1 specification could result in severe injury from breakage of eye protection.



6. **Stopping the Lathe.** **DO NOT** try and stop the lathe by using your hand against the piece part. **Always** allow the lathe to stop on its own.
7. **Respiratory Protection.** Wear an approved dust mask or respirator while using this machine. Continued exposure to wood dust can cause allergies or long term respiratory problems.
8. **Dress appropriate.** **DO NOT** wear loose fitting clothing or jewelry as they can be caught in moving machine parts. Protective clothing and steel toe shoes are recommended when using machinery. Wear a restrictive hair covering to contain long hair.
9. **Mounting Piece Part.** Before starting the machine, make sure the piece part has been properly secured to the headstock and tailstock of the lathe. **Check** for adequate clearance as the piece rotates.
10. **Adjusting Tool Rest.** Adjust the tool rest to provide for proper support of the tool you will be using. Test clearance of the tool rest by rotating the piece part by hand before turning the lathe ON.
11. **Remove any adjusting tools.** Before operating the machine, make sure any adjusting tools have been removed.
12. **Sanding Polishing.** Remove the tool rest before performing polishing or sanding operations.
13. **Keep work area clean.** Cluttered areas invite injuries.
14. **Overloading machine.** By overloading the machine you may cause injury from flying parts. **DO NOT** exceed the specified machine capacities.
15. **Material Removal Rate.** Attempting to remove too much material at once can cause the piece part to fly out of the lathe causing **severe bodily injury.**
16. **Turning Speed.** Select the correct turning speed for your work. Always allow the lathe to reach full speed before beginning an operation.
17. **Use Sharp Tooling.** Keep chisels and other tooling properly sharpened and held firmly while turning.
18. **Do not overreach.** Maintain proper footing and balance at all times. **DO NOT** reach over or across a running machine.
19. **Stay alert.** Watch what you are doing and use common sense. **DO NOT** operate any tool or machine when you are tired.
20. **Maintenance and Adjustments.** Before starting any inspection, adjustment, or maintenance procedure **MAKE SURE** the lathe is **OFF**, has come to a complete stop, and the electrical has been properly **LOCKED OUT.**
21. **Check for damaged parts.** Before using any tool or machine, carefully check any part that appears damaged. Check for binding of moving parts that may affect proper machine operation.



22. **Reducing Piece Part Vibration.** If the piece part vibrates while turning, immediately turn the lathe **OFF**. Check that the piece part is properly centered and balanced. Trim off excess waste to help balance the piece. **Make Sure** piece part is secured.
23. **Observe work area conditions.** **DO NOT** use machines or power tools in damp or wet locations. Do not expose to rain. Keep work area well lighted. **DO NOT** use electrically powered tools in the presence of flammable gases or liquids.
24. **DO NOT** bypass or defeat any safety interlock systems.
25. Keep visitors a safe distance from the work area.
26. **Keep children away.** Children must never be allowed in the work area. **DO NOT** let them handle machines, tools, or extension cords.
27. Know the location of the **ON - OFF** switch and the “E”- **STOP** button.
28. **DO NOT operate machine if under the influence of alcohol or drugs.** Read warning labels on prescriptions. If there is any doubt, **DO NOT** operate the machine.
29. **DO NOT** touch live electrical components or parts.
30. **Be Sure** all equipment is properly installed and grounded according to national, state, and local codes. If machine is equipped with a three-prong plug, it should be plugged into a three-hole electrical receptacle. If an adapter is used to accommodate a two-prong receptacle, the adapter plug must be attached to a known ground. Never remove the third prong.
31. Inspect power and control cables periodically. Replace if damaged or bare wires are exposed. **Bare wiring can kill!**
32. **Faceplate Turning.** When faceplate turning, use the lathe chisels on the downward spinning side of the piece part **ONLY**.
33. **Maintain machine in top condition.** Keep clean for best and safest performance. Follow instructions for lubricating and changing accessories.
34. **Reduce the risk of unintentional starting.** Make sure switch is in “**OFF**” position before plugging in power cord.
35. **Never leave machine running unattended. TURN POWER OFF.** Don't leave machine until it comes to a complete stop.
36. **Make sure machine is disconnected from power supply** while motor is being mounted, connected or reconnected.
37. **Inspect Piece Part.** Always inspect piece part for staples, nails, knots, or other imperfections that could become projectiles causing personal injury. Carefully Inspect piece parts that have been glued for a good bond.
38. **Warning:** The dust generated by certain woods and wood products can be injurious to your health. Always operate machinery in well ventilated areas and provide for proper dust removal. Use a wood dust collection system whenever possible.



TECHNICAL SPECIFICATIONS

Over Bed	18" (460mm)
Swing Over Tool Rest Base	14" (356mm)
Distance Between Centers	47" (1200mm)
Speeds (RPM)	0 – 1200 & 0 – 3200
Spindle Nose	1-1/4" x 8 TPI (M33 x 3.5)
Drive Spindle Through Hole	3/8" (10mm)
Tailstock Spindle Through Hole	3/8" (10mm)
Tailstock Spindle Travel	4" (110mm)
Tool Rest	14" (355mm)
Face Plate	6" (152mm)
Headstock Taper	MT-2
Tailstock Taper	MT-2
Spindle Center to Floor (approx.)	44.29" ~ 46.85" (1125 ~ 1190mm)
Power Supply	220V, 1ph, 60hz
Motor	2 hp (1.5kw), 220V, 1ph, 60hz, 5.3A
Inverter	VFD-M-1.5kw Input Power 230V Only
Net Weight (approx.)	419 lbs. (190 kgs.)
Shipping Weight (approx.)	585 lbs. (265 kgs)

TECHNICAL SUPPORT

Our technical support department can be reached at 920.684.4990 and asking for the support desk for purchased machines. Tech Support handles questions on machine setup, schematics, warranty issues, and individual parts needs: (other than die sets and blades).

For specific application needs or future machine purchases contact the Sales Department at: sales@baileigh.com, Phone: 920.684.4990, or Fax: 920.684.3944.



Note: *The photos and illustrations used in this manual are representative only and may not depict the actual color, labeling or accessories and may be intended to illustrate technique only.*



Note: *The specifications and dimensions presented here are subject to change without prior notice due to improvements of our products.*



UNPACKING AND CHECKING CONTENTS

Your Baileigh machine is shipped complete. Separate all parts from the packing material and check each item carefully. Make certain all items are accounted for before discarding any packing material.

⚠ WARNING: SUFFOCATION HAZARD! Immediately discard any plastic bags and packing materials to eliminate choking and suffocation hazards to children and animals.
If any parts are missing, **DO NOT** place the machine into service until the missing parts are obtained and installed correctly.

Cleaning

⚠ WARNING: DO NOT USE gasoline or other petroleum products to clean the machine. They have low flash points and can explode or cause fire.

⚠ CAUTION: When using cleaning solvents work in a well-ventilated area. Many cleaning solvents are toxic if inhaled.

Your machine may be shipped with a rustproof waxy coating and/or grease on the exposed unpainted metal surfaces. Fully and completely remove this protective coating using a degreaser or solvent cleaner. Moving items will need to be moved along their travel path to allow for cleaning the entire surface. For a more thorough cleaning, some parts will occasionally have to be removed. **DO NOT USE** acetone or brake cleaner as they may damage painted surfaces.

Follow manufacturer's label instructions when using any type of cleaning product. After cleaning, wipe unpainted metal surfaces with a light coating of quality oil or grease for protection.



Important: This waxy coating is **NOT** a lubricant and will cause the machine to stick and lose performance as the coating continues to dry.





Before assembling, read the manual thoroughly, familiarizing yourself with correct assembly and maintenance procedures and proper safety precautions.

Contents of shipping cartons:

Container

- 1 Lathe
- 1 Tailstock
- 1 Headstock
- 1 Tool Rest Body
- 1 Owner's Manual

Accessory Package Carton

- 1 Live Center
- 1 Spur Center
- 1 Index Pin
- 1 Face Plate
- 1 Knockout Rod Headstock
- 1 Tool Rest

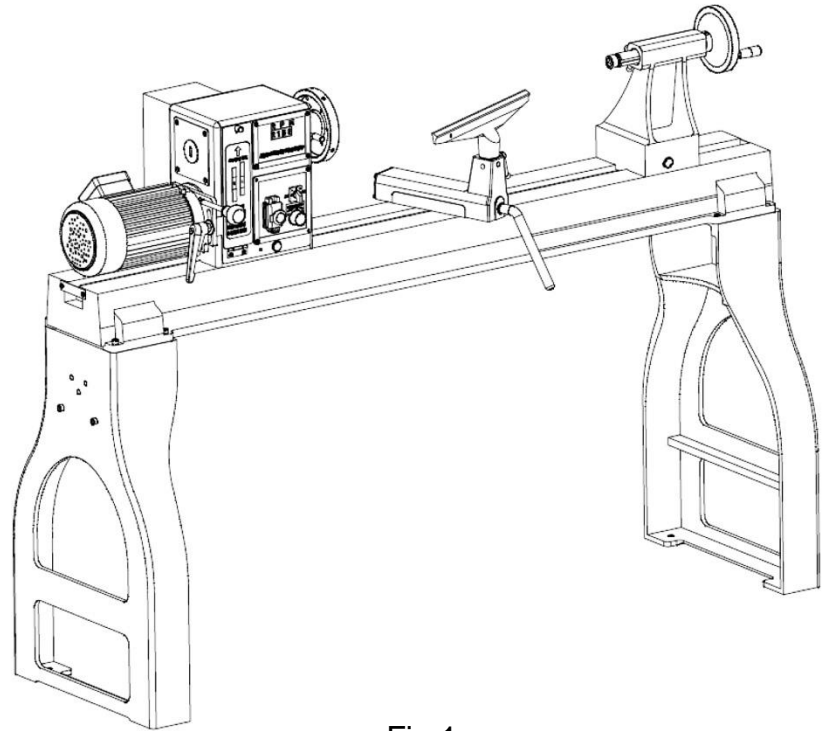

Fig 1.

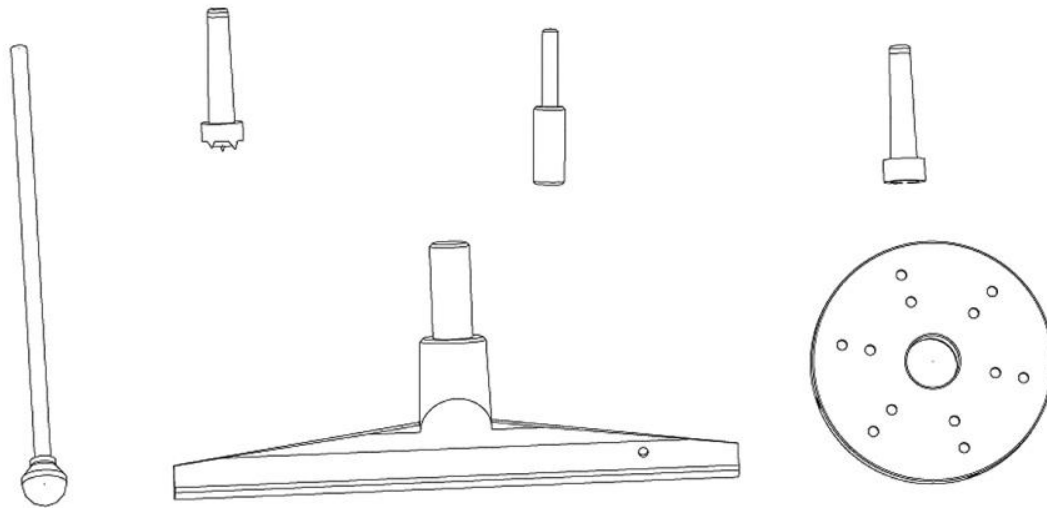

Fig 2.



ASSEMBLY

⚠ WARNING: FOR YOUR OWN SAFETY, DO NOT CONNECT THE MACHINE TO THE POWER SOURCE UNTIL THE MACHINE IS COMPLETELY ASSEMBLED AND YOU READ AND UNDERSTAND THE ENTIRE INSTRUCTION MANUAL.

1. Secure tool rest (A, Fig. 3) to tool rest body (B, Fig. 3) by tightening handle (C, Fig. 3).

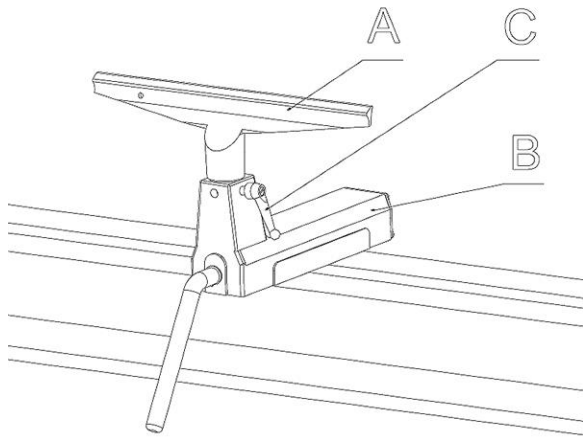

Fig 3.

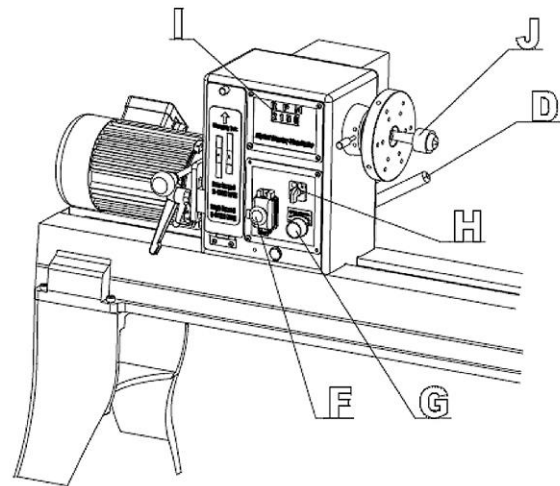

Fig 4.



TRANSPORTING AND LIFTING

NOTICE: *Lifting and carrying operations should be carried out by skilled workers, such as a truck operator, crane operator, etc. If a crane is used to lift the machine, attach the lifting chain carefully, making sure the machine is well balanced.*

Follow these guidelines when lifting with truck or trolley:

- The lift truck must be able to lift at least 1.5 – 2 times the machines gross weight.
- Make sure the machine is balanced. While transporting, avoid rough or jerky motion, and maintain a safe clearance zone around the transport area.
- Use a fork lift with sufficient lifting capacity and forks that are long enough to reach the complete width of the machine.
- Remove the securing bolts that attach the machine to the pallet.
- Approaching the machine from the side, lift the machine on the frame taking care that there are no cables or pipes in the area of the forks.
- Move the machine to the required position and lower gently to the floor.
- Level the machine so that all the supporting feet are taking the weight of the machine and no rocking is taking place.

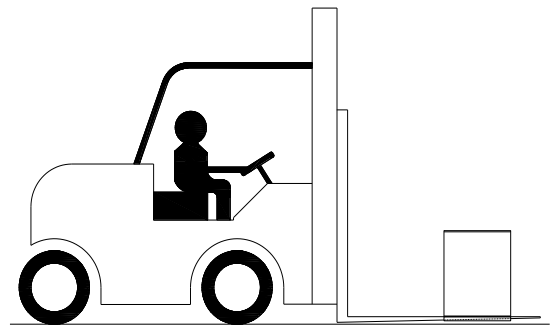

INSTALLATION

IMPORTANT:

Consider the following when looking for a suitable location to place the machine:

- Overall weight of the machine.
- Weight of material being processed.
- Sizes of material to be processed through the machine.
- Space needed for auxiliary stands, work tables, or other machinery.
- Clearance from walls and other obstacles.
- Maintain an adequate working area around the machine for safety.
- Have the work area well illuminated with proper lighting.
- Keep the floor free of oil and make sure it is not slippery.



- Remove scrap and waste materials regularly, and make sure the work area is free from obstructing objects.
- It is important to maintain free area around the machine, which is required for the working place. If any long material is machined, it is necessary to have a sufficient room in front of the machine as well behind it in the places of material input and output.
- **LEVELING:** The machine should be sited on a level, concrete floor. Provisions for securing it should be in position prior to placing the machine. The accuracy of any machine depends on the precise placement of it to the mounting surface.
- **FLOOR:** This machine distributes a large amount of weight over a small area. Make certain that the floor is capable of supporting the weight of the machine, work stock, and the operator. The floor should also be a level surface. If the unit wobbles or rocks once in place, be sure to eliminate by using shims.
- **WORKING CLEARANCES:** Take into consideration the size of the material to be processed. Make sure that you allow enough space for you to operate the machine freely.
- **POWER SUPPLY PLACEMENT:** The power supply should be located close enough to the machine so that the power cord is not in an area where it would cause a tripping hazard. Be sure to observe all electrical codes if installing new circuits and/or outlets.

Securing the Base



WARNING: Before operating; make sure it is positioned firmly on a solid level floor. If it tips over on you, it could cause severe injury or death.

The machine should be sited on a level, concrete floor. The accuracy of any machine depends on the precise placement of it to the mounting surface.

Place shims under the four feet mounted in the base as required for leveling.

Using the holes in the mortiser base, the mortiser should be secured to the stand with four M12 x 120 hex head screws provided. Make sure there is enough room on each side of the mortiser for the size stock you plan to use.



GETTING TO KNOW YOUR MACHINE

The Baileigh Wood Lathe ML-1847VS adjustable speed wood lathes is a big capacity machine, designed for industry, commercial shops, and schools, or wherever a demand exists for continued accuracy and long life through safe, heavy-duty operation.

1. **Headstock Lock Handle:** (D, Fig.4) Locks head in position. Unlock handle to position the head along lathe bed. Tighten handle when properly positioned.
2. **Headstock On/Off Button:** (F, Fig.4) Pull the button out to turn "ON" the lathe. Push the button in to turn the lathe "OFF".
3. **Headstock RPM Knob:** (G, Fig. 4) Turn knob to desired RPM. There are two speed ranges offering "speed" (330-3200) and "torque" (100-1200).
4. **Headstock For/Rev Switch:** (H, Fig. 4) Use the toggle switch to change the direction the spindle turns. Only change direction when the spindle has stopped.

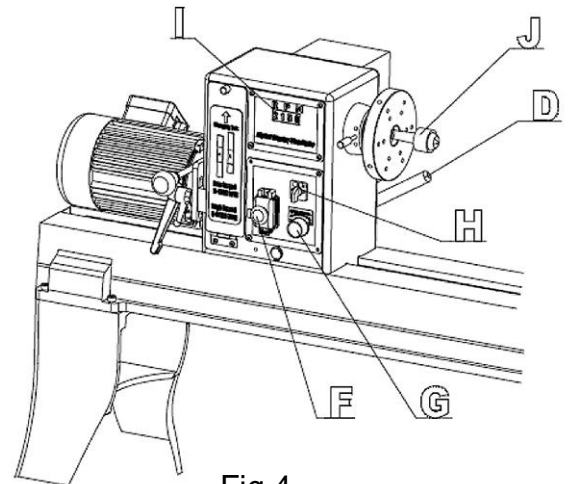

Fig 4.

5. **Headstock RPM Readout:** (I, Fig. 4) Displays the spindles RPM, see Figure 5.

Diameter of Work	Roughing RPM	General Cutting RPM	Finishing RPM
Under 2"	1520	3200	3200
2 to 4"	760	1600	2480
4 to 6"	510	1080	1650
6 to 8"	380	810	1240
8 to 10"	300	650	1000
10 to 12"	255	540	830
12 to 14"	220	460	710
14 to 16"	190	400	620

Fig 5.

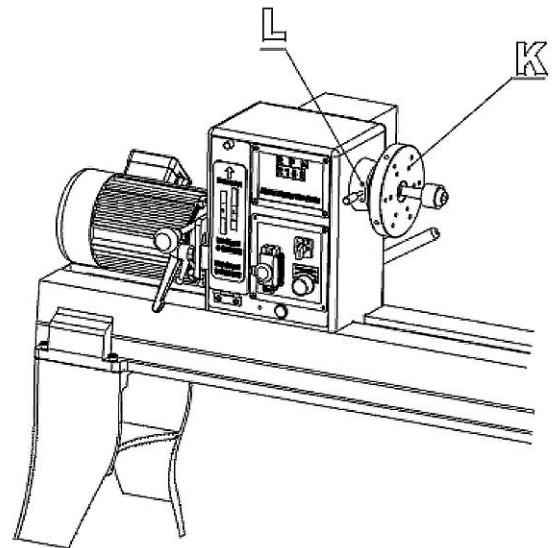

Fig 6.

6. **Headstock Spur Center:** (J, Fig. 6) Used for turning between centers. Spindle taper is MT-2. Remove spur center by inserting drift rod through the opposite end of the spindle and knocking spur center out.



- Headstock Faceplate:** (K, Fig. 6) Used for turning bowls and plates. There are a number of screw holes for mounting the workpiece. Thread the faceplate onto the spindle in a clockwise direction and tighten two set screws. Remove the faceplate by loosening two set screws. Push in headstock spindle lock and use the provided rod in faceplate holes to unthread the faceplate.

⚠ CAUTION: Never start the lathe with the index pin engaged in the spindle!

- Headstock Indexing Hole:** (L, Fig. 6) Thread indexing pin into the indexing hole making sure that it locates in the spindle hole. There are 12 holes in the spindle 30° apart. There are three holes in the headstock casting that accept the indexing pin. These holes are 20° apart. The combination of holes will allow you to mark your work piece for evenly spaced features.

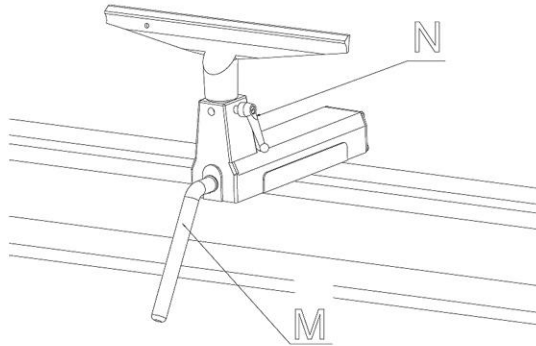

Fig 7.

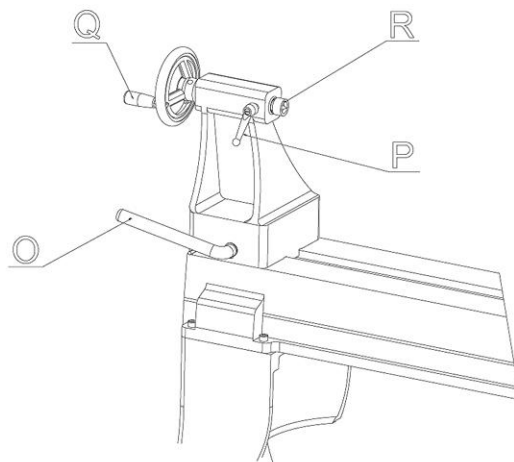



Fig 8.

- Tool Rest Body Lock Handle:** (M, Fig. 7) Locks the tool rest body in position. Unlock handle to position the tool rest in any location along lathe bed. Tighten handle when properly positioned.
- Tool Rest Lock Handle:** (N, Fig. 7) Locks the tool rest in position. Unlock the handle to position tool rest at a specific angle, or height. Tighten handle when properly positioned.
- Tailstock Lock Handle:** (O, Fig. 8) Locks the tailstock in position. Unlock handle to position the tool rest in any location along lathe bed. Tighten handle when properly positioned.
- Tailstock Quill Lock Handle:** (P, Fig. 8) Locks the tailstock quill in position. Unlock handle to position the quill. Tighten handle when properly positioned.
- Tailstock Quill Handwheel:** (Q, Fig. 8) Turn the handwheel to position the quill. The tailstock quill lock handle must be loose to position quill.
- Tailstock Live Center:** (R, Fig. 8) Used for turning between centers. Quill taper is MT-2. Remove live center by retracting the quill until live center loosens. Remove, or add different tips to the live center by inserting the provided rod through.



ELECTRICAL

 **CAUTION:** HAVE ELECTRICAL UTILITIES CONNECTED TO MACHINE BY A CERTIFIED ELECTRICIAN!
Check if the available power supply is the same as listed on the machine nameplate.

 **WARNING:** Make sure the grounding wire (green) is properly connected to avoid electric shock. DO NOT switch the position of the green grounding wire if any electrical plug wires are switched during hookup.

Power Specifications

Your machine is wired for 220 volts, 60hz alternating current. Before connecting the machine to the power source, make sure the power source is OFF.

Before switching on the power, you must check the voltage and frequency of the power to see if they meet with the requirement, the allowed range for the voltage is $\pm 5\%$, and for the frequency is $\pm 1\%$.

Considerations

- Observe local electrical codes when connecting the machine.
- The circuit should be protected with a time delay fuse or circuit breaker with a amperage rating slightly higher than the full load current of machine.
- A separate electrical circuit should be used for your machine. Before connecting the motor to the power line, make sure the switch is in the "OFF" position and be sure that the electric current is of the same characteristics as indicated on the machine.
- All line connections should make good contact. Running on low voltage will damage the motor.
- In the event of a malfunction or breakdown, grounding provides a path of least resistance for electric current to reduce the risk of electric shock. This machine is equipped with an electric cord having an equipment-grounding conductor and a grounding plug. The plug must be plugged into a matching outlet that is properly installed and grounded in accordance with all local codes and ordinances.

 **WARNING:** In all cases, make certain the receptacle in question is properly grounded. If you are not sure, have a qualified electrician check the receptacle.



- Improper connection of the equipment-grounding conductor can result in risk of electric shock. The conductor with insulation having an outer surface that is green with or without yellow stripes is the equipment-grounding conductor. If repair or replacement of the electric cord or plug is necessary, do not connect the equipment-grounding conductor to a live terminal.
- Check with a qualified electrician or service personnel if the grounding instructions are not completely understood, or if in doubt as to whether the machine is properly grounded.
- Repair or replace damaged or worn cord immediately.

Extension Cord Safety

Extension cord should be in good condition and meet the minimum wire gauge requirements listed below:

AMP RATING	LENGTH		
	25ft	50ft	100ft
1-12	16	16	14
13-16	14	12	12
17-20	12	12	10
21-30	10	10	No
WIRE GAUGE			

An undersized cord decreases line voltage, causing loss of power and overheating. All cords should use a ground wire and plug pin. Replace any damaged cords immediately.

Power cord connection:

1. Turn the main disconnect switch on the control panel to the OFF position.
2. Unwrap the power cord and route the cord away from the machine toward the power supply.
 - a. Route the power cord so that it will NOT become entangled in the machine in any way.
 - b. Route the cord to the power supply is a way that does NOT create a trip hazard.
3. Connect the power cord to the power supply and check that the power cord has not been damaged during installation.
4. When the machine is clear of any obstruction. The main power switch may be turn ON to test the operation. Turn the switch OFF when the machine is not in operation.



WIRING DIAGRAM

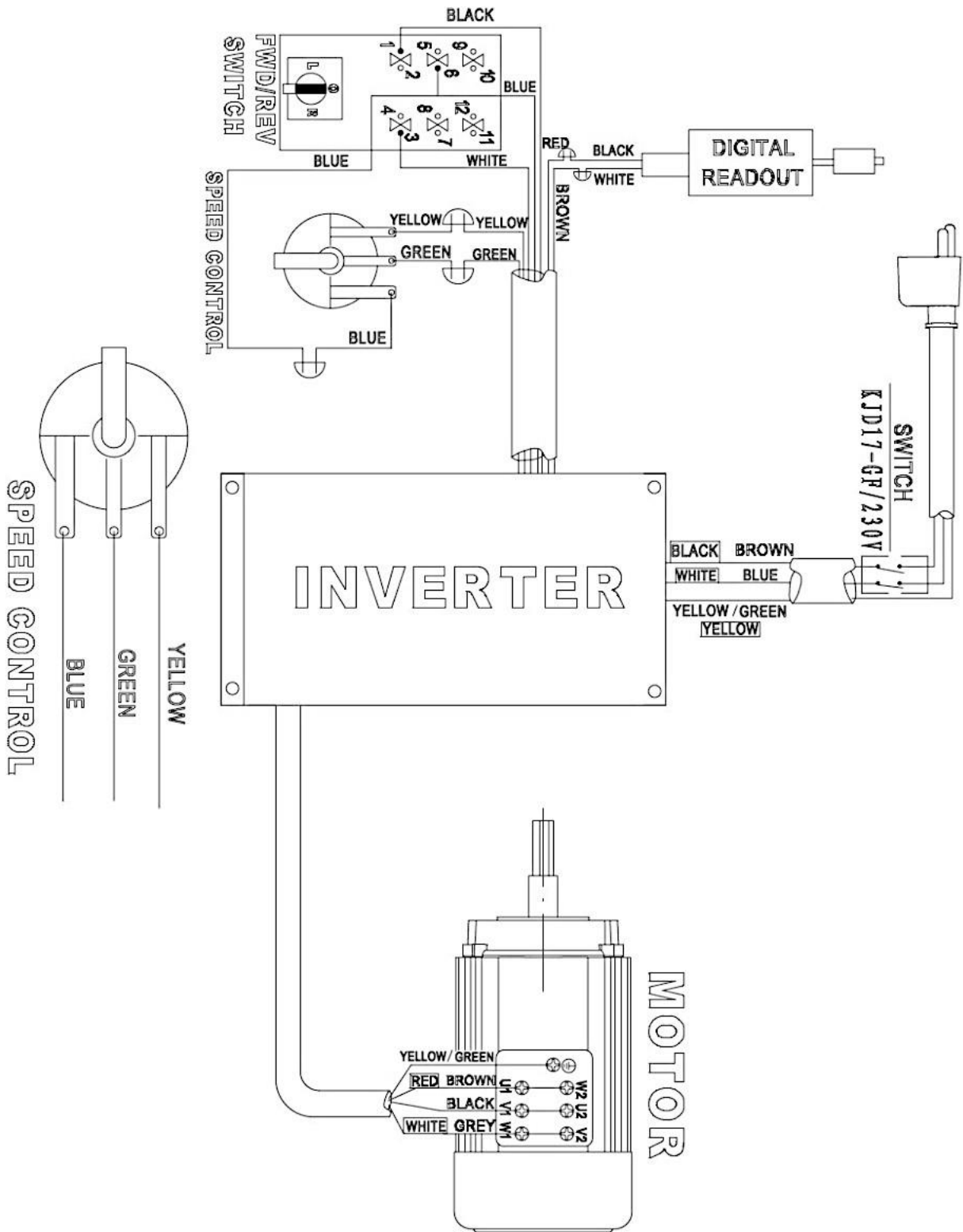



CHANGING SPEEDS

1. Disconnect the machine from the power source!
2. Loosen the locking handle (A, Fig. 9).
3. Lift up on the tensioning handle (B, Fig. 9) to remove tension from the poly v-belt. You can now position the belt in the desired speed range. It is pictured in the low speed pulley range. Note: The "High" speed range (330-3200) provides maximum speed, where as the "Low" speed range (100-1200) will provide maximum torque.
4. Lower the tensioning handle so that the weight of the motor provides the needed tension and tighten the locking handle.

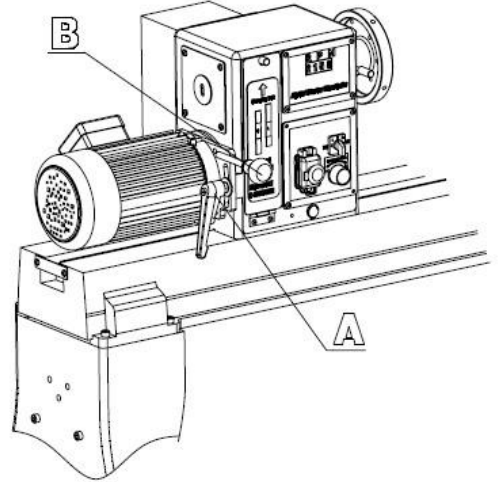

Fig 9.

OPERATION

The following directions will give the inexperienced operator a beginning point for common lathe operations. Practice on scrap material before attempting serious work.



CAUTION: Always wear proper personal protection equipment, including but not limited to, safety eye protection with side shields, face shield, safety footwear, and leather gloves to protect from, chips, dust, burrs, and slivers.

LATHE TOOLS

Standard wood turning tools come in several different configurations (Fig. 10). The majority of turnings will require the gouge tool (A) Fig. 10. This round nosed hollow chisel is used for roughing cuts, cove cuts and other operations. The skew chisel (B) is a double-ground flat chisel, with an angled end. This tool is used for smoothing cylinders, for cutting shoulders, beads, vee grooves, etc. The parting tool (C) is a double-ground chisel, used for cutting-off, or for making straight incisions or sizing cuts to any required diameter. The round nose scraper (D) is used for mostly hollowing work, while the square-end scraper is mainly used for the outside of bowls.

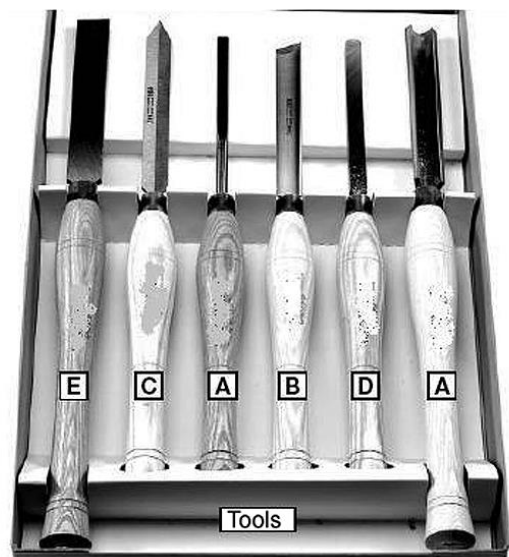

Fig 10.



HOW TO TURN SPINDLES

Working with any material that is attached to the lathe centers is called a spindle turning. This is the principal type of wood turning (chair and table legs, lamp stems, etc.) The turning of spindles can be done with either a scraping or cutting technique.

The cutting technique, by virtue of faster wood removal and a cleaner surface, is the preferred method.

CENTERING THE WORK

Wood stock for any spindle turning should be approximately square, and the ends should be square with the sides. Two common methods of determining the center are shown in Figs. 11 and 12.

In Fig. 11, a distance a little more or a little less than one-half the width of the stock is set off from each of the four sides. The small square set off in the center can then be used in marking the true center.

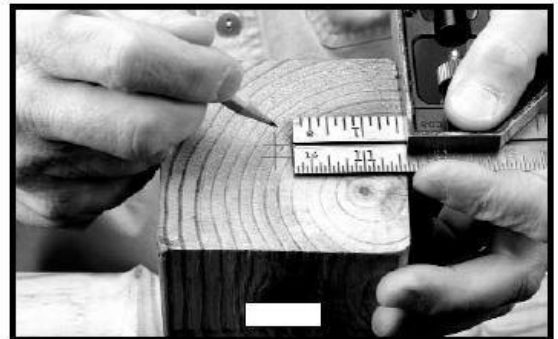

Fig 11.

The diagonal method, Fig. 12, consists of drawing lines from corner to corner, with the intersection marking the center of the work.



Fig 12.

After marking each end, mark the true center with a punch awl or dividers (Fig. 13). If the stock is hardwood, the centers should be drilled to a depth of about 1/8".

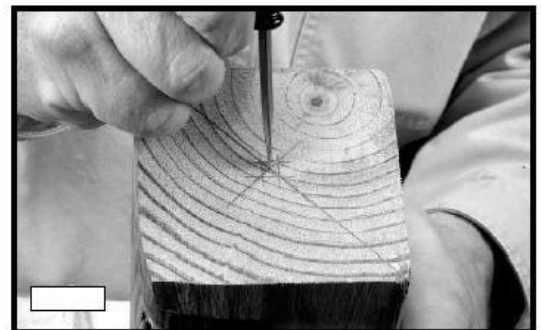

Fig 13.



The spur or live center is then placed against one end of the work and seated by striking with a mallet (Fig. 14). In hardwood, make a starting seat for the spur center by sawing on the diagonal lines, and drilling a small hole at the intersection. After driving the center, hold the center and the work together and fit both immediately to headstock spindle. If you are not using a ball bearing center, the end of work at tailstock center should be oiled. Place the lubricant on the wood either before or after it is put on the lathe. Many turners use beeswax, tallow, or a wax-and-oil mixture as a lubricant.



Fig 14.

A ball bearing center is ideal because it eliminates lubricating. If the work is to be removed from the lathe before completion, an index mark should be made as a guide for re-centering (Fig. 15). A permanent indexer can be made by grinding off one corner of one of the spurs.



Fig 15.

TOOL REST POSITION

Mount the tool rest in place about $1/8$ " away from the work and $1/8$ " above the work centerline (Fig. 16.) This position may be varied to suit the work and the operator. Place a guide mark on the tool rest shank as an aid to quick and accurate resetting.

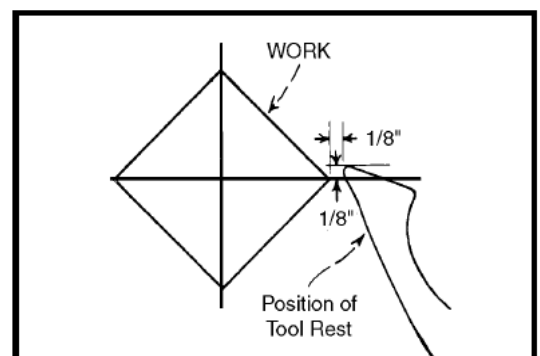

Fig 16.



ROUGHING A CYLINDER

The large gouge is used in the first turning operation by smoothing the sharp corners of the work. Run the lathe at low speed and hold the gouge in the manner shown in Fig. 17.

The cut starts about 2 inches from the tailstock end and continues from this point to the end of the tailstock. Make the second pass beginning about 2" or 3" to the left of the first cut. Advance again toward the tailstock, and merge with the previous cut.



Fig 17.

Toward the end of the live center, roll the gouge in the opposite direction (Fig. 18) to carry the final cut off the live center end of the work. The roughing cut should not be carried out with one continuous movement, because this would tear long slivers from the corners of the work. Neither should the cut be started directly at the end of the stock for the same reason. The cut can be safely carried from the center of the stock toward and off either end once the first roughing cuts have been made. The position of the gouge involves two or three important angles.



Fig 18.

1. The tool may be advanced along the work either from right to left or from left to right. Left to right (from headstock to tailstock) is preferred since this action throws chips clear of the operator.
2. The gouge is rolled over slightly in the same direction it is advancing.
3. The tool is held well up on the work, with the bevel or grind tangent to the revolving surface (Fig. 19). This position will give a clean shearing cut. When pushed straight into the work (Fig. 19), the gouge has a scraping action, (normally a poor practice in spindle turning). The roughing cut is continued until the work approaches 1/8" of the required diameter. Once a cylindrical form has been obtained, the turning speed can be moved to the second or third speed setting.

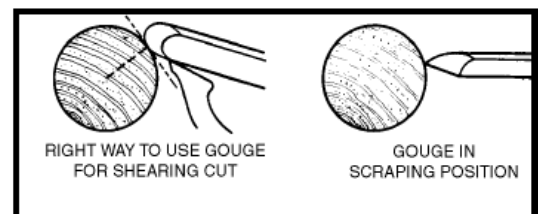

Fig 19.



Note: Continue to move the tool rest inward toward the work piece to keep the safe distance between the two.



POSITION OF HANDS

While turning, the hand that holds the tool handle should be in a natural position. This hand provides the leverage for the tool by either moving in toward the chisel or moving out. The position of the tool rest hand is more a matter of individual preference, rather than a “set” or “proper” position. However, a palm-up grip (Fig. 20) is generally considered best. In this position, the first finger acts as a guide, sliding along the tool rest as the cut is made.

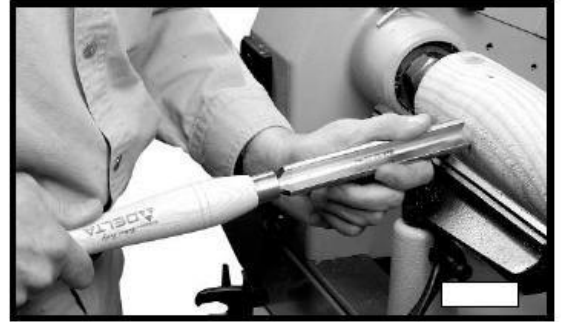

Fig 20.

The alternate position is a palm-down grip (Fig. 21). In this position, the heel of the hand or the little finger serves as a guide. The palm-down position is solid and positive – excellent for roughing or heavy cutting. Most beginners start with the palm-down grip, switching later to the palm-up position for better manipulation of the chisel.



Fig 21.

SMOOTHING A CYLINDER

To smooth a cylinder, use a large skew chisel. This requires practice, but experience with this tool is very important. Place the cutting point near the center of chisel and high on the work (Fig. 22). Sometimes, in striving for a certain position in relation to the work, the beginner will often overlook this all-important point. Raising the handle will increase the depth of cut while lowering the handle, of course, does the opposite. As with the gouge, the skew can be advanced in either direction. The center of the skew toward the heel does the actual cutting. The back portion of the grind or bevel supports the tool, while the handle-hand controls the depth of cut by rocking the chisel on this pivot point. Because of this, keep the skew bevel perfectly flat.



Fig 22.



OWNER MADE OPTIONS

User-Made Shelf

The double ledges on the inside of the new lathe legs provide support for a shelf, which is convenient for storing larger items while keeping them easily accessible.

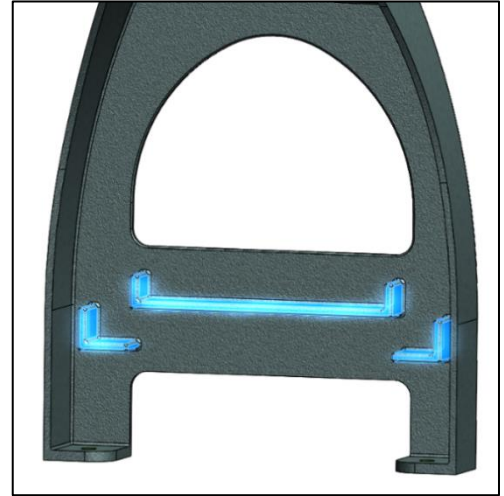

Shelf Styles for reference.

Shelf Style 1: Lay two boards flat upon the inner ledges.

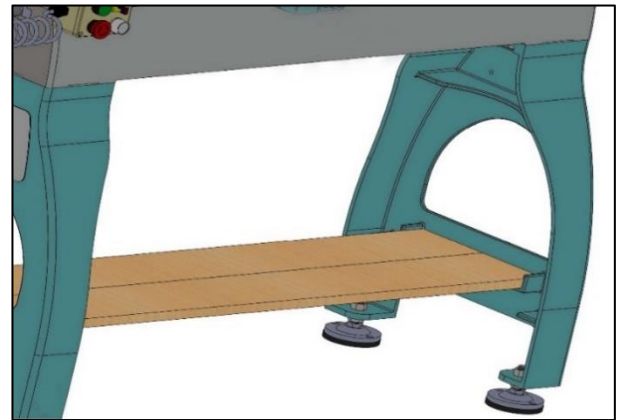

Shelf Style 2: Lay two boards on edge into the outer ledges. Cut two pieces from a plywood board and screw them to the top edges of the two boards. Make the plywood pieces flush with the outside edge of the two boards.





Shelf Style 3: A basket-style shelf consisting of two boards and dowel rods. The advantage of this design is that most wood chips will fall through the shelf instead of accumulating on it.

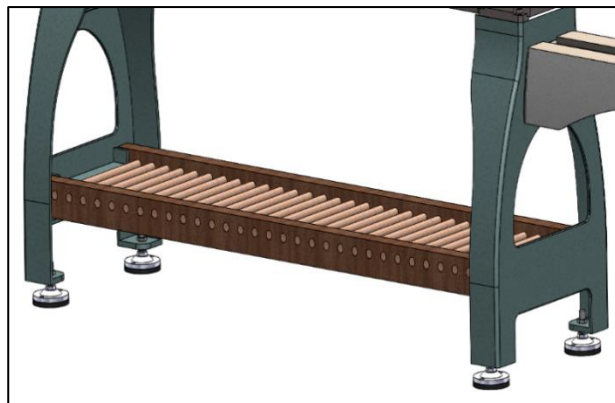

MAINTENANCE



WARNING: Make sure the electrical disconnect is **OFF** before working on the machine.
Maintenance should be performed on a regular basis by qualified personnel.
Always follow proper safety precautions when working on or around any machinery.

Daily Maintenance

- Do a general cleaning by removing dust and chips from the machine.
- Check and tighten any loose mounting bolts.
- Sharpen or replace any worn or damaged tooling.
- Inspect the power plug and cord.
- Keep area around machine clear of debris.
- Check for any unsafe conditions and fix immediately.
- Check that all nuts and bolts are properly tightened.



Note: When cleaning chips and debris from the machine, use a brush and a shop vacuum. **DO NOT** blow off the machine with compressed air. The force of the compressed air may force chips into critical mechanisms or may inflict injury to yourself or others.

Monthly Maintenance

- Check that all screws and bolts are tight and secure.
- Check for worn or damaged electrical cables.



Note: Proper maintenance can increase the life expectancy of your machine.



TROUBLESHOOTING

⚠ WARNING: Make sure the electrical disconnect is **OFF** before working on the machine.

Problem	Possible Cause	Solution
Excessive Vibration.	<ol style="list-style-type: none"> 1. Work piece warped, out of round, has major flaw, or was improperly prepared for turning 2. Worn spindle bearings 3. Worn belt 4. Motor mount bolt or handle loose 5. Lathe on uneven surface 	<ol style="list-style-type: none"> 1. Correct problem by planing, band sawing, or scrap workpiece all together 2. Replace bearings 3. Replace belt 4. Tighten bolt or handle 5. Shim lathe bed, or adjust feet on stand
Motor or Spindle Stalls or Will not Start	<ol style="list-style-type: none"> 1. Excessive cut 2. Worn motor 3. Broken belt 4. Worn spindle bearings 5. Improper cooling on motor 	<ol style="list-style-type: none"> 1. Reduce cut depth 2. Replace motor 3. Replace belt 4. Replace bearings 5. Clean sawdust from motor fan
Motor fails to develop full power.	<ol style="list-style-type: none"> 1. Power line overloaded 2. Undersize wires in supply system 3. Low voltage 4. Worn motor 	<ol style="list-style-type: none"> 1. Correct overload condition 2. Increase supply wire size 3. Request voltage check from power company and correct low voltage condition 4. Replace motor
Tools tend to grab or dig in.	<ol style="list-style-type: none"> 1. Dull tools 2. Tool support set too low 3. Tool support set too far from work piece 4. Improper tool being used 	<ol style="list-style-type: none"> 1. Sharpen tools 2. Reposition tool support height 3. Reposition tool support closer to workpiece 4. Use correct tool for operation
Digital readout does not work	<ol style="list-style-type: none"> 1. Digital readout sensor out of position 	<ol style="list-style-type: none"> 1. Open the belt access and position the sensor so that it reads the bolts



STAND AND BED ASSEMBLY

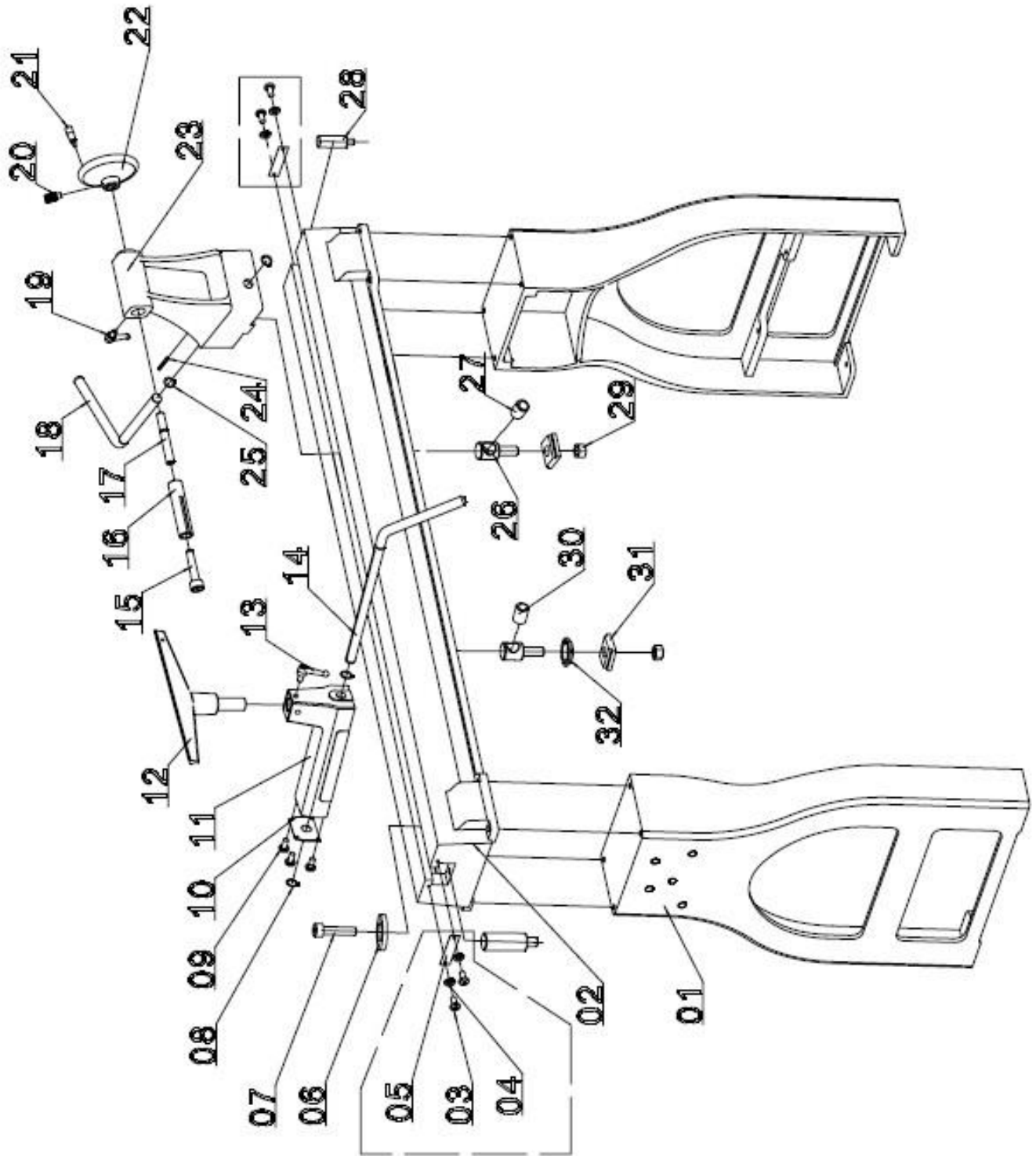



Parts List

Item	Item	Description	Qty.
1	WL1847VS-1V2	Stand	2
	WL1847VS-1FP2	Foot Pad Ø100mm, M16	4
2	WL1847VS-2	Bed	1
3	WL1847VS-3	Screw M5 x 12	4
4	WL1847VS-4	Spring Washer M5	4
5	WL1847VS-5	Baffle	2
6	WL1847VS-6	Spring Washer M10	8
7	WL1847VS-7	Cap Screw M10 x 35	8
8	WL1847VS-8	C-Ring C-19	2
9	WL1847VS-9	Set Screw M5 x 10	4
10	WL1847VS-10	Baffle	1
11	WL1847VS-11	Tool Rest Body	1
12	WL1847VS-12	Tool Rest	1
13	WL1847VS-13	Tool Support Handle	1
14	WL1847VS-14	Tool Support Rod	1
15	WL1847VS-15	Center	1
16	WL1847VS-16	Quill	1
17	WL1847VS-17	Lead Screw	1
18	WL1847VS-18	Tailstock Rod	1
19	WL1847VS-19	Tailstock Quill Handle	1
20	WL1847VS-20	Set Screw M8 x 12	1
21	WL1847VS-21	Handle	1
22	WL1847VS-22	Handle wheel	1
23	WL1847VS-23	Tailstock	1
24	WL1847VS-24	Pin	1
25	WL1847VS-25	C-Ring C-19	2
26	WL1847VS-26	Clamp Bolt	2
27	WL1847VS-27	Bushing	1
28	WL1847VS-28	Shaft	2
29	WL1847VS-29	Hex Nut M18	2
30	WL1847VS-30	Bushing	1
31	WL1847VS-31	Clamp	2
32	WL1847VS-32	Support Bracket	1



HEADSTOCK ASSEMBLY

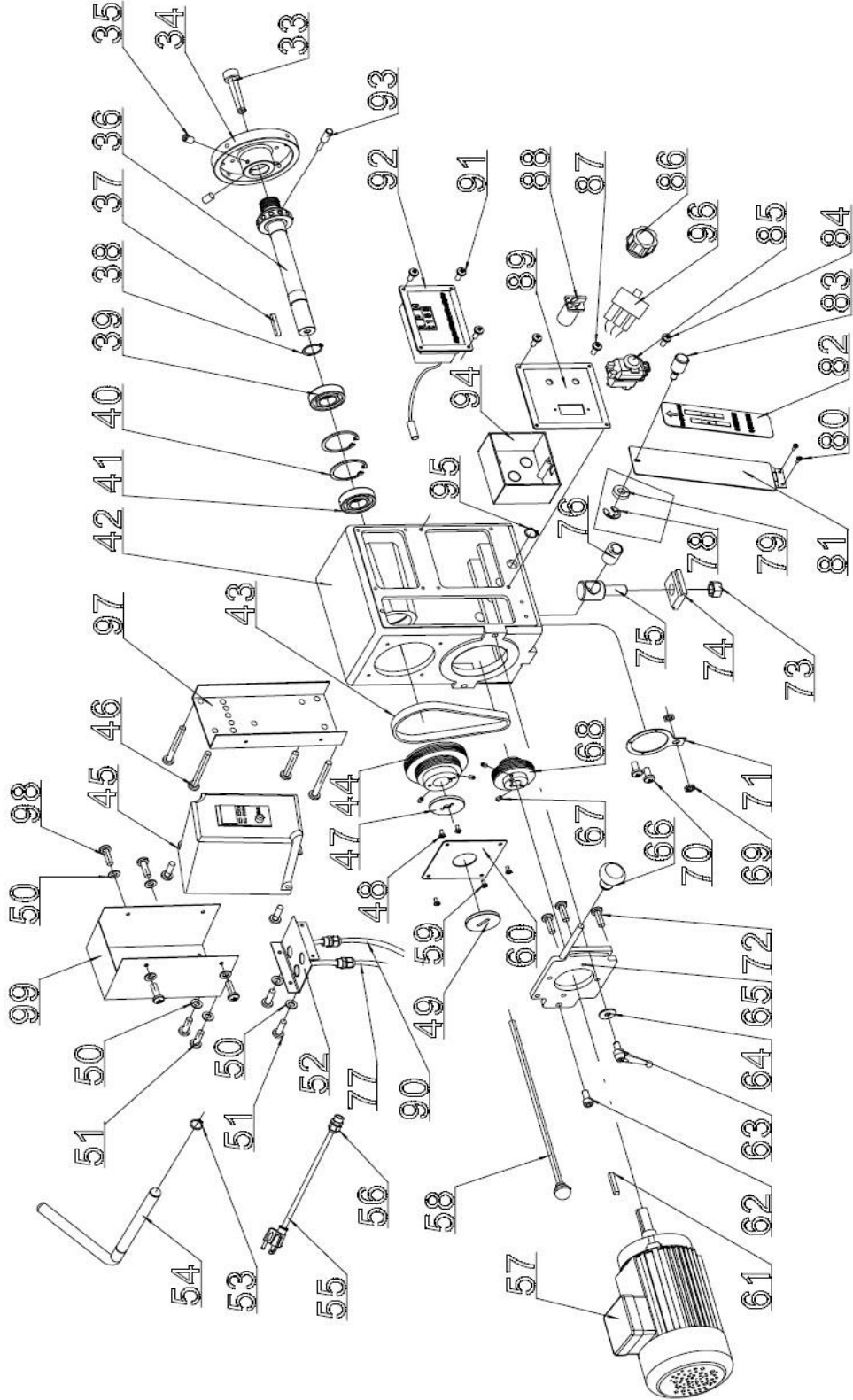



Parts List

Item	Part No.	Description	Qty.
33	WL1847VS-33	Headstock Spur	1
34	WL1847VS-34	Faceplate	1
35	WL1847VS-35	Set Screw M6 x 12	2
36	WL1847VS-36	Spindle	1
37	WL1847VS-37	Key C 8 x 7 x 45	1
38	WL1847VS-38	C-Ring C-30	1
39	WL1847VS-39	Bearing 6206	1
40	WL1847VS-40	C-Ring C-62	2
41	WL1847VS-41	Bearing 6206	1
42	WL1847VS-42	Headstock	1
43	WL1847VS-43	Poly-V Belt 530J6	1
44	WL1847VS-44	Spindle Pulley	1
45	WL1847VS-45	Inverter	1
46	WL1847VS-46	Screw M5 x 30	4
47	WL1847VS-47	Cover A	1
48	WL1847VS-48	Screw M5 x 12	2
49	WL1847VS-49	Cover B	1
50	WL1847VS-50	Washer	8
51	WL1847VS-51	Screw M4 x 8	8
52	WL1847VS-52	Cord Bracket	1
53	WL1847VS-53	C-Ring C-19	2
54	WL1847VS-54	Lever	1
55	WL1847VS-55	Power Cord	1
56	WL1847VS-56	Strain Relief	5
57	WL1847VS-57	Motor	1
58	WL1847VS-58	Knockout Rod	1
59	WL1847VS-59	Screw M5 x 12	4
60	WL1847VS-60	Plate	1
61	WL1847VS-61	Key 6 x 6 x 48	1
62	WL1847VS-62	Cap Screw M10 x 30	1
63	WL1847VS-63	Handle	1
64	WL1847VS-64	Washer M10	2
65	WL1847VS-65	Motor Assembly Plate	1



Item	Part No.	Description	Qty.
66	WL1847VS-66	Knob	1
67	WL1847VS-67	Set Screw M6 x 12	2
68	WL1847VS-68	Motor Pulley	1
69	WL1847VS-69	Nut M12 x 1	2
70	WL1847VS-70	Screw M4 x 8	2
71	WL1847VS-71	Bracket For Sensor	4
72	WL1847VS-72	Set Screw M8 x 20	4
73	WL1847VS-73	Hex Nut M18	1
74	WL1847VS-74	Clamp	1
75	WL1847VS-75	Clamp Bolt	1
76	WL1847VS-76	Bushing	1
78	WL1847VS-78	Washer	1
79	WL1847VS-79	Washer	2
80	WL1847VS-80	Screw M5 x 12	2
81	WL1847VS-81	Belt Door	1
82	WL1847VS-82	Speed Label	1
83	WL1847VS-83	Knob or Screw M5 x 12	1
84	WL1847VS-84	Screw M4 x 10	4
85	WL1847VS-85	On/Off Switch - KJD17B	1
86	WL1847VS-86	Variable Speed Knob	1
87	WL1847VS-87	Screw M4 x 10	2
88	WL1847VS-88	Fwd/Rev Switch ZH-A	1
89	WL1847VS-89	Panel Cover	1
90	WL1847VS-90	Screw M4 x 10	2
91	WL1847VS-91	Screw M4 x 10	4
92	WL1847VS-92	Digital Readout	1
93	WL1847VS-93	Hex Head Bolt	1
94	WL1847VS-94	Switch Box	2
95	WL1847VS-95	C-Ring C-19	1
96	WL1847VS-96	Variable Speed Control	1
	WL1847VS-Duplicator	Copier/Duplicator Attachment (Optional)	
	WL1847VS-OTR	Outboard Tool Rest (Optional)	



NOTES

BAILEIGH INDUSTRIAL HOLDINGS LLC
1625 DUFEK DRIVE MANITOWOC, WI 54220
PHONE: 920. 684. 4990 FAX: 920. 684. 3944
www.baileigh.com